

The logo for the San Francisco Arts Commission, featuring the lowercase letters 'sfac' in a white, stylized, sans-serif font on a red square background.

san francisco
arts commission

San Francisco Arts Commission Visual Arts Committee Meeting

May 15, 2024

Item 1: Call to Order, Roll Call, Agenda Changes, Land Acknowledgement

- Call to order
- Roll call / Confirmation of quorum
- Agenda Changes
- Ramaytush Ohlone Land Acknowledgement

Land Acknowledgement

The San Francisco Arts Commission acknowledges that we are on the unceded ancestral homeland of the Ramaytush Ohlone who are the original inhabitants of the San Francisco Peninsula. As the indigenous stewards of this land and in accordance with their traditions, the Ramaytush Ohlone have never ceded, lost nor forgotten their responsibilities as the caretakers of this place, as well as for all peoples who reside in their traditional territory. As guests, we recognize that we benefit from living and working on their traditional homeland. We wish to pay our respects by acknowledging the ancestors, elders and relatives of the Ramaytush Community and by affirming their sovereign rights as First Peoples. As a department dedicated to promoting a diverse and equitable Arts and Culture environment in San Francisco, we are committed to supporting the traditional and contemporary evolution of the American Indian community.



Antone Family (Tohono O'odham), 2019, Photo by Hulleah Tsinhnahjinnie
Left to right: Christine [seated], Melanie, Michelle and Arianna

Item 2: General Public Comment

Discussion

(This item is to allow members of the public to comment generally on matters within the Committee's purview as well as to suggest new agenda items for the committee's consideration.)

Public Comment

Item 2: General Public Comment

Item 3: Consent Calendar

Discussion and Possible Action

Presentation Time: Approximately 3 minutes

Item 3: Consent Calendar

Discussion and Possible Action

***Please see Agenda to review the 72 motions on the consent calendar*

Public Comment

Item 3: Consent Calendar

Item 3: Consent Calendar

Action

Motion to approve the consent calendar items.

Item 4: Sunnydale Hope SF – California Bear over Head of Peace sculpture relocation

Discussion and Possible Action

Presenter: Senior Registrar Allison Cummings

Presentation Time: Approximately 6 minutes

Discussion and possible action to approve the proposed new location for "California Bear over Head of Peace," a black granite sculpture by Beniamino Bufano at the former Sunnydale Housing Project – now Sunnydale Hope SF. The sculpture will be relocated from the entryway to the former Leasing Office to a more prominent location in front of the new Community Center on the corner of Jackson Way and Sunnydale Avenue, as a part of the larger housing reconstruction project.



Sunnydale Community Center SF Visual Arts Commission

May 15, 2024

CURRENT PHASE

Sunnydale Avenue Infrastructure

- 4-acre grading, street, utility project
- *Completion early 2024*

Community Center

- 30,000 SF community center
- Boys & Girls Club
- Wu Yee Children's Services
- Recording Studio
- Living Room & Multipurpose Rooms
- *Completion late 2024*

3A & 3B Mixed-Use Buildings

- 170 units affordable housing
- 20,000 SF ground floor commercial space
- *Completion Early 2025*

Herz Recreation Center

- 12,000 SF recreation center
- Full-size Basketball Court
- *Completion mid 2025*

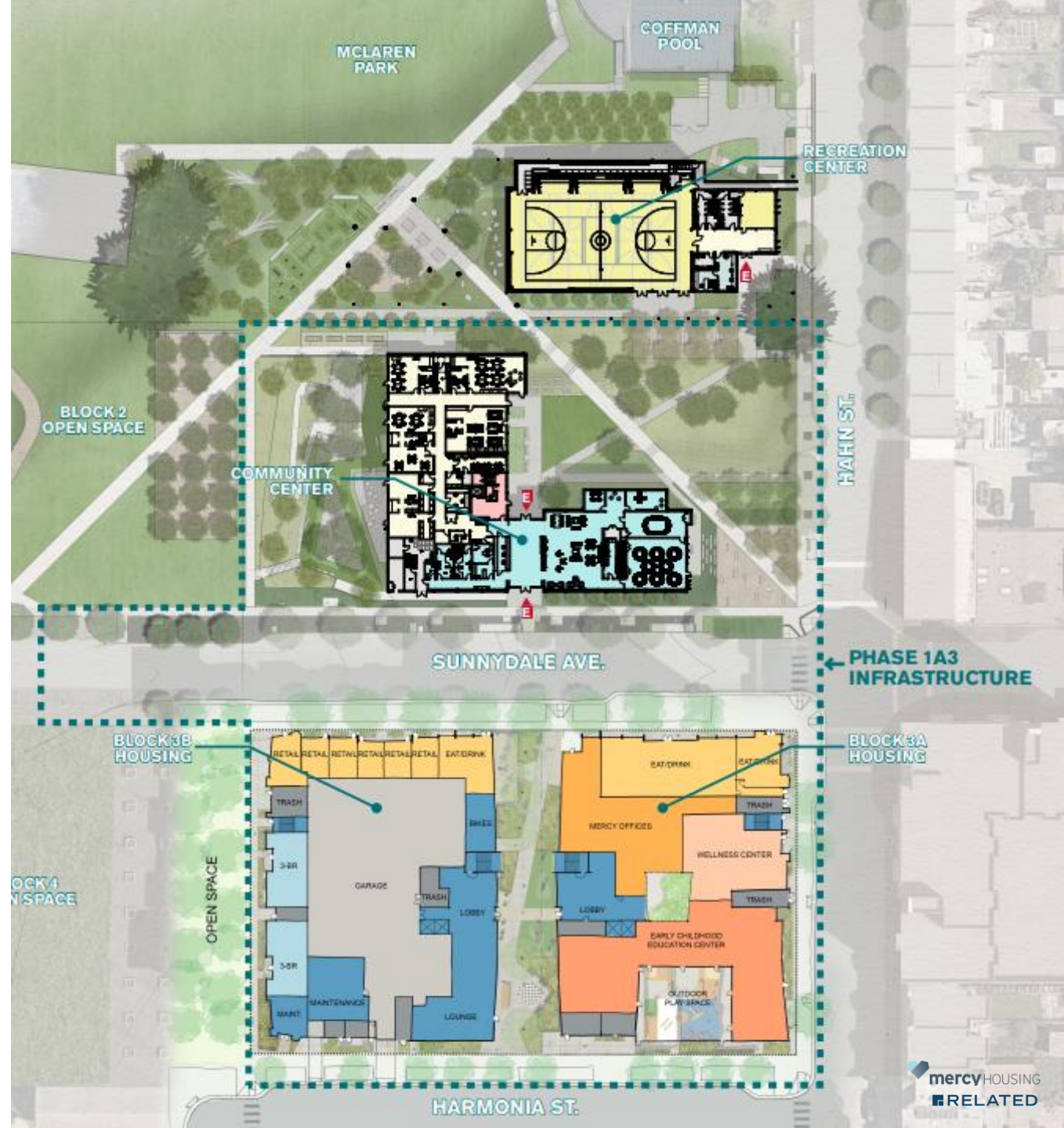

COMMUNITY CENTER & RECREATION CENTER



COMMUNITY CENTER & RECREATION CENTER

Community Center with Community Kitchen

Boys & Girls Club

Recreation Center with 10,000 square foot gym

Recording Studio

Wu Yee Early Childhood Education Center



Community Center



Sunnydale Avenue Main entrance

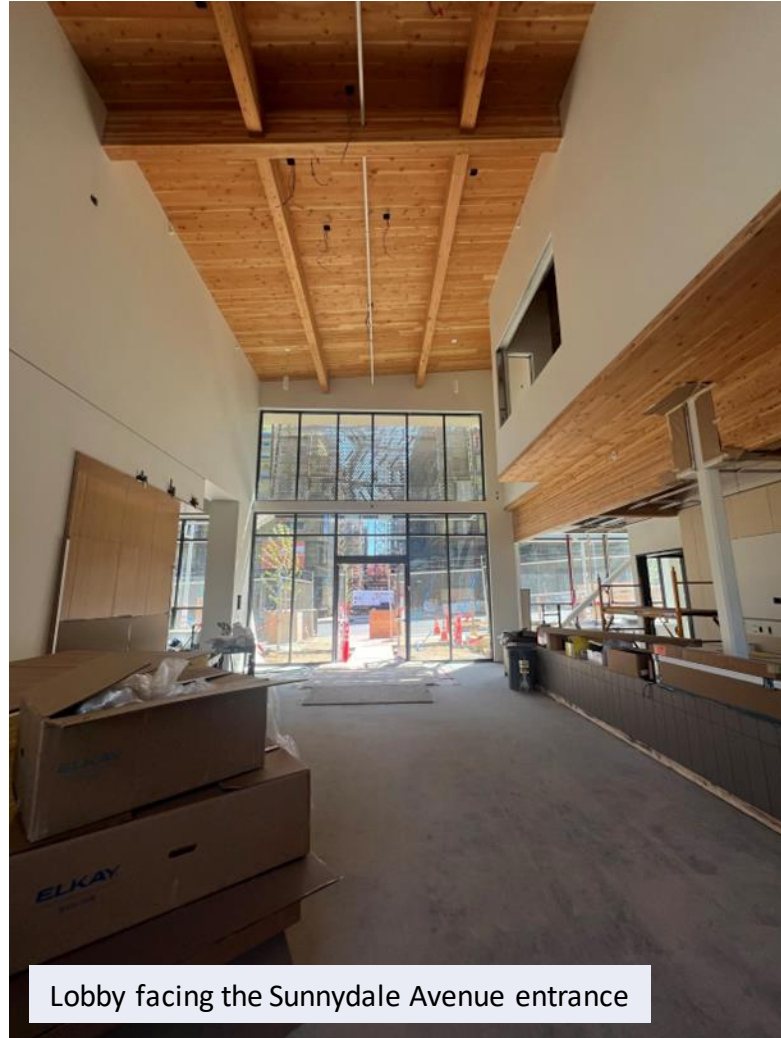

Lobby facing the Sunnydale Avenue entrance



Courtyard view

- Community center construction is expected to reach TCO in August 2024 and final completion in October 2024
- The development is 79% into construction

Current Conditions of the Benny Bufano Sculpture

April 17, 2024 at 3:01 PM
San Francisco - Crocker-Amazon - 5,018 of 5,019



April 17, 2024 at 3:01 PM
San Francisco - Crocker-Amazon - 5,019 of 5,019



April 17, 2024 at 3:01 PM
San Francisco - Crocker-Amazon - 5,017 of 5,019



Relocation

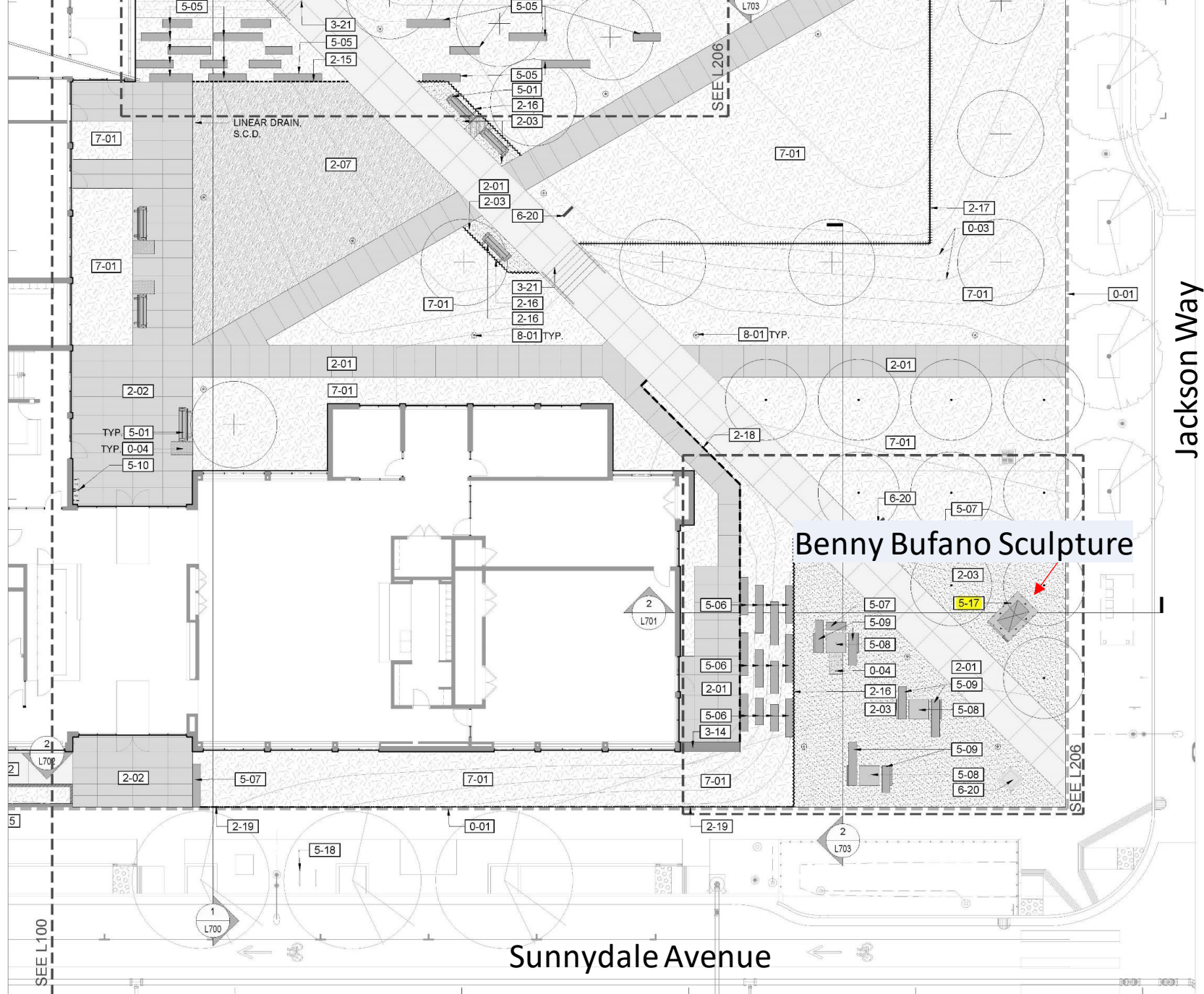

Jackson Way

Sunnydale Avenue

SYMBOL	DESCRIPTION
2-08	EWB PAVING
2-09	PLAY SURFACING
EDGES	
SYMBOL	DESCRIPTION
2-14	EDGE TYPE I
2-15	EDGE TYPE II
2-16	EDGE TYPE III
2-17	EDGE TYPE IV
2-18	EDGE TYPE V
2-19	EDGE TYPE VI
WALLS	
SYMBOL	DESCRIPTION
3-11	WALL TYPE I
3-12	WALL TYPE II
3-13	WALL TYPE III
3-14	WALL TYPE IV
3-15	WALL TYPE V
STAIRS	
SYMBOL	DESCRIPTION
3-21	STAIR TYPE I
3-23	STAIR TYPE 3
3-24	STAIR TYPE II
5 SITE FURNISHINGS	
SYMBOL	DESCRIPTION
5-01	BENCH
5-03	PICNIC TABLE
5-05	STONE ELEMENT TYPE I
5-06	STONE ELEMENT TYPE II
5-07	STONE ELEMENT TYPE III
5-08	STONE ELEMENT TYPE IV
5-09	STONE ELEMENT TYPE V
5-10	WASTE RECEPTACLES
5-11	RECLAIMED TIMBER ELEMENT
5-12	BOULDER
5-13	PLAYGROUND SLIDE
5-14	PLANTER
5-15	RECLAIMED WOOD STEPPER
5-16	WATER FOUNTAIN
5-17	BUFANO SCULPTURE PLINTH
5-18	BIKE RACKS
FENCES + GUARDRAILS	
SYMBOL	DESCRIPTION
6-01	FENCE TYPE I
6-02	GUARDRAIL
6-03	GATE TYPE I
6-04	GATE TYPE II
6-20	SIGNAGE ELEMENT
7 PLANTING	
SYMBOL	DESCRIPTION
7-01	PLANTING AREA
8 SITE LIGHTING	
SYMBOL	DESCRIPTION
8-01	SITE LIGHTING FIXTURE



Benny Bufano Signage



Benny Bufano Signage



Drawings

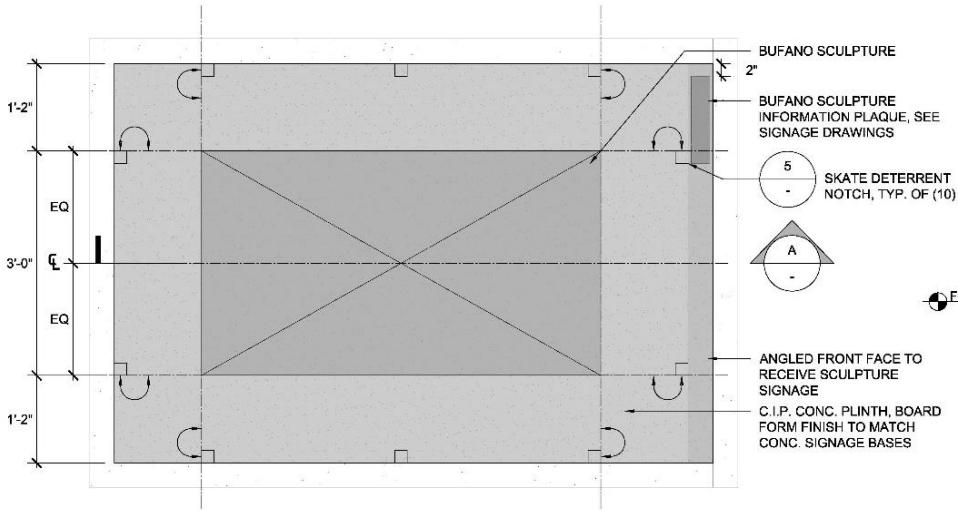

PLAN



NOTE: FIELD VERIFY DIMENSIONS OF SCULPTURE. WEIGHT OF SCULPTURE TO BE DETERMINED TO FINALIZE PLINTH DIMENSIONS AND STRUCTURAL REQUIREMENTS.

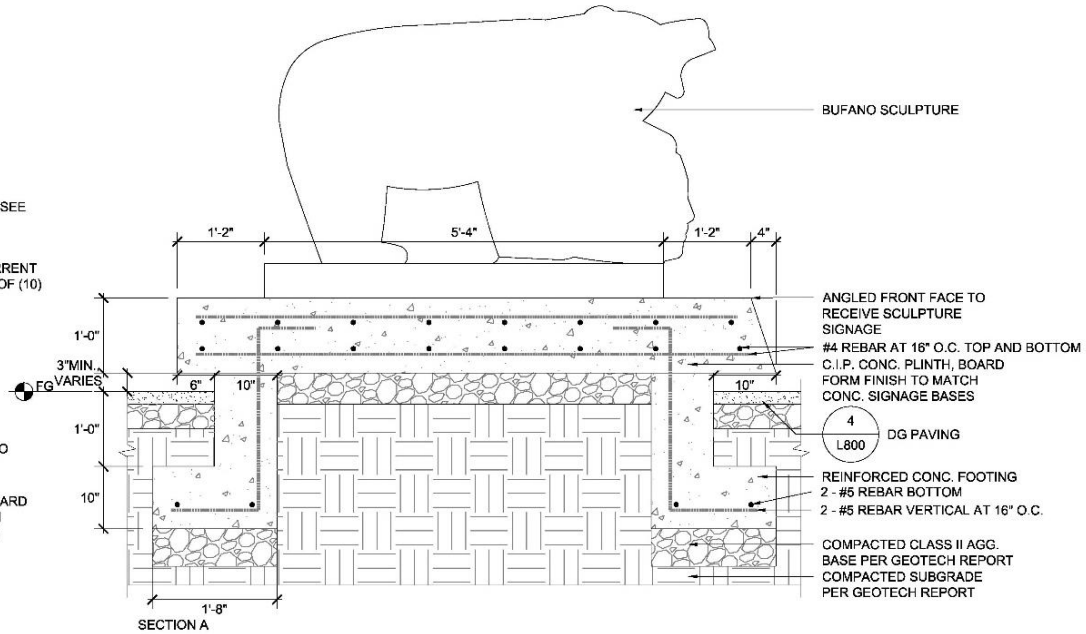

SECTION A

BUFANO SCULPTURE

ANGLED FRONT FACE TO RECEIVE SCULPTURE SIGNAGE

#4 REBAR AT 16" O.C. TOP AND BOTTOM
C.I.P. CONC. PLINTH, BOARD FORM FINISH TO MATCH CONC. SIGNAGE BASES

4
L800
DG PAVING

REINFORCED CONC. FOOTING
2 - #5 REBAR BOTTOM
2 - #5 REBAR VERTICAL AT 16" O.C.

COMPACTED CLASS II AGG. BASE PER GEOTECH REPORT
COMPACTED SUBGRADE PER GEOTECH REPORT

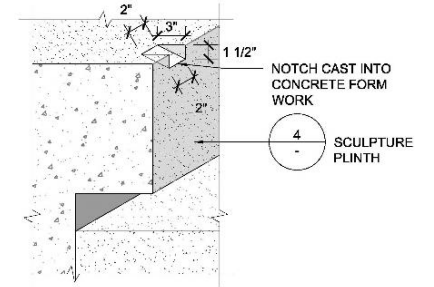

Questions?

Public Comment

Item 4: Sunnydale Hope SF – California Bear over Head of Peace sculpture relocation

Item 4: Sunnydale Hope SF – California Bear over Head of Peace sculpture relocation

Action

Motion to approve the proposed new location for "California Bear over Head of Peace," a black granite sculpture by Beniamino Bufano at the former Sunnydale Housing Project – now Sunnydale Hope SF. The sculpture will be relocated from the entryway to the former Leasing Office to a more prominent location in front of the new Community Center on the corner of Jackson Way and Sunnydale Avenue, as a part of the larger housing reconstruction project.

Item 5: 2024 Art on Market Street Poster Series

Discussion and Possible Action

Presenter: Program Associate Craig Corpora

Presentation Time: Approximately 6 minutes

Discussion and possible action to approve the 10 final designs by Kirti Bassendine for the 2024 Art on Market Street Poster Series.

2024 Art on Market Street Poster Series

Kirti Bassendine
We Are Still Here

we are still here



Gregg Castro
Cultural Director

The Association of Ramaytush Ohlone

We are each placed in our Original Homelands by the wisdom of the Creator. The knowledge to steward our Origin Lands was given to us by the First People, who shaped the world the Creator gifted them with. These Original Instructions have been passed down to us by the Ancestors. The most important of these teachings is that we are to be grateful and humble for this gift of land and life. We are joined together with land and sky by an unbreakable bond.



www.ramaytush.org



© Kirti Bassendine 2024.
Poster Design by Melissa Bari
kirtibassendinephotography.com

The San Francisco Arts Commission acknowledges that we are on the unceded ancestral homeland of the Ramaytush Ohlone. We affirm the sovereign rights of their community as First Peoples and are committed to supporting the traditional and contemporary evolution of the American Indian community and uplifting contemporary Indigenous voices and culture.



The Art on Market Street Poster Series is a project of the San Francisco Arts Commission and the SF Municipal Transit Authority.

we are still here



Corrina Gould

Traditional Tribal Leader / Tribal Chair
Confederated Villages of Lisjan Nation

It wasn't until about 25 years ago that we really began making an imprint in the Bay Area by telling our own stories as Lisjan people. Archaeologists and historians have been telling our history through their own lands, voices and academic ways that erase us by talking about us as the past. We started to educate the people in the Bay Area about whose land they're on, what their responsibility is to the First Nation peoples of those lands, to stop desecration and to remember us as human beings again.



www.villagesoflisjan.org



© Kiri Bassendine 2024
Poster Design by heavenstee.com
heavenstee.com photography.com

The San Francisco Arts Commission acknowledges that we are on the unceded ancestral homeland of the Ramaytush Ohlone. We affirm the sovereign rights of their community as First Peoples and are committed to supporting the traditional and contemporary evolution of the American Indian community and uplifting contemporary Indigenous voices and culture.



The Art on Market Street Poster Series is a project of the San Francisco Arts Commission and the SF Municipal Transit Authority

we are still here

Monica V. Arellano

Tribal Vice Chairwoman
Muwekma Ohlone Tribe of the San Francisco Bay Area

We Are Of This Land; We Are The Land! As stewards of our ancestral homeland, we care for the earth and all the living creatures and plant life on it. One cannot exist without the other. The San Francisco Bay Area was an oasis where our people thrived for thousands of years. Today, we continue in our traditional ways, speak our native languages, share our knowledge, and protect the ecology. The land keeps us alive. We protect and care for it, and pass on that responsibility to the next generation. **We Are Still Here! Mákkin Mak Nommo!**



www.muwekma.org



© Kiri Bassendine 2024.
Poster Design by Heather Fay
kiri.bassendinephotography.com

The San Francisco Arts Commission acknowledges that we are on the unceded ancestral homeland of the Ramaytush Ohlone. We affirm the sovereign rights of their continuity as First Peoples and are committed to supporting the traditional and contemporary evolution of the American Indian community and uplifting contemporary Indigenous voices and culture.



The Art on Market Street Poster Series is a project of the San Francisco Arts Commission and the SF Municipal Transit Authority.

we are still here



Quirina Luna Geary

Chairwoman
Tamien Nation

We are Tamien Nation, direct descendants of the San Francisco South Bay. Since time immemorial, we have honored our agreement with the world, rooted in respect and reciprocity. Our dedication to environmental protection and restoration remains unwavering. Tamien Nation's wildland firefighters tirelessly protect our local communities and contribute to the restoration of our ecology. We remain steadfast in doing our part, working alongside agencies to combat climate change to secure a sustainable future for all.



www.tamien.org

 Kirti
© Kirti Bassendine 2024.
Poster Design by Neerata Ban
kirtibassendinephotography.com

The San Francisco Arts Commission acknowledges that we are on the unceded ancestral homeland of the Ramaytush Ohlone. We affirm the sovereign rights of their community as First Peoples and are committed to supporting the traditional and contemporary evolution of the American Indian community and uplifting contemporary Indigenous voices and culture.

 sfac

The Art on Market Street Poster Series is a project of the San Francisco Arts Commission and the SF Municipal Transit Authority.

we are still here



Kanyon Sayers-Roods

Chairwoman
Indian Canyon Chualar Tribe of the Costanoan People

amah piretakawas - a title, a responsibility, the essence of being Ohlone. **To Honor the Past to Shape the Future** is not just a Call to Remember, but a Directive to Act. This Land, vibrant with the Spirits of Our Ancestors, demands from all **Good Ancestors In Training** more than passive acknowledgment. By the **Rights of Nature**, you, also, as visitors on this Land, bear the obligation to provide Active Engagement, a Commitment to Preserve, Protect, and Partner with the Original Stewards and Original People of this sacred Earth.



www.costanoan.org



© Kiri Bassendine 2024
Poster Design by Melissa Sam
kribassendinephotography.com

The San Francisco Arts Commission acknowledges that we are on the unceded ancestral homeland of the Ramaytush Ohlone. We affirm the sovereign rights of their community as First Peoples and are committed to supporting the traditional and contemporary evolution of the American Indian community and uplifting contemporary Indigenous voices and culture.



The Art on Market Street Poster Series is a project of the San Francisco Arts Commission and the SF Municipal Transit Authority.

we are still here

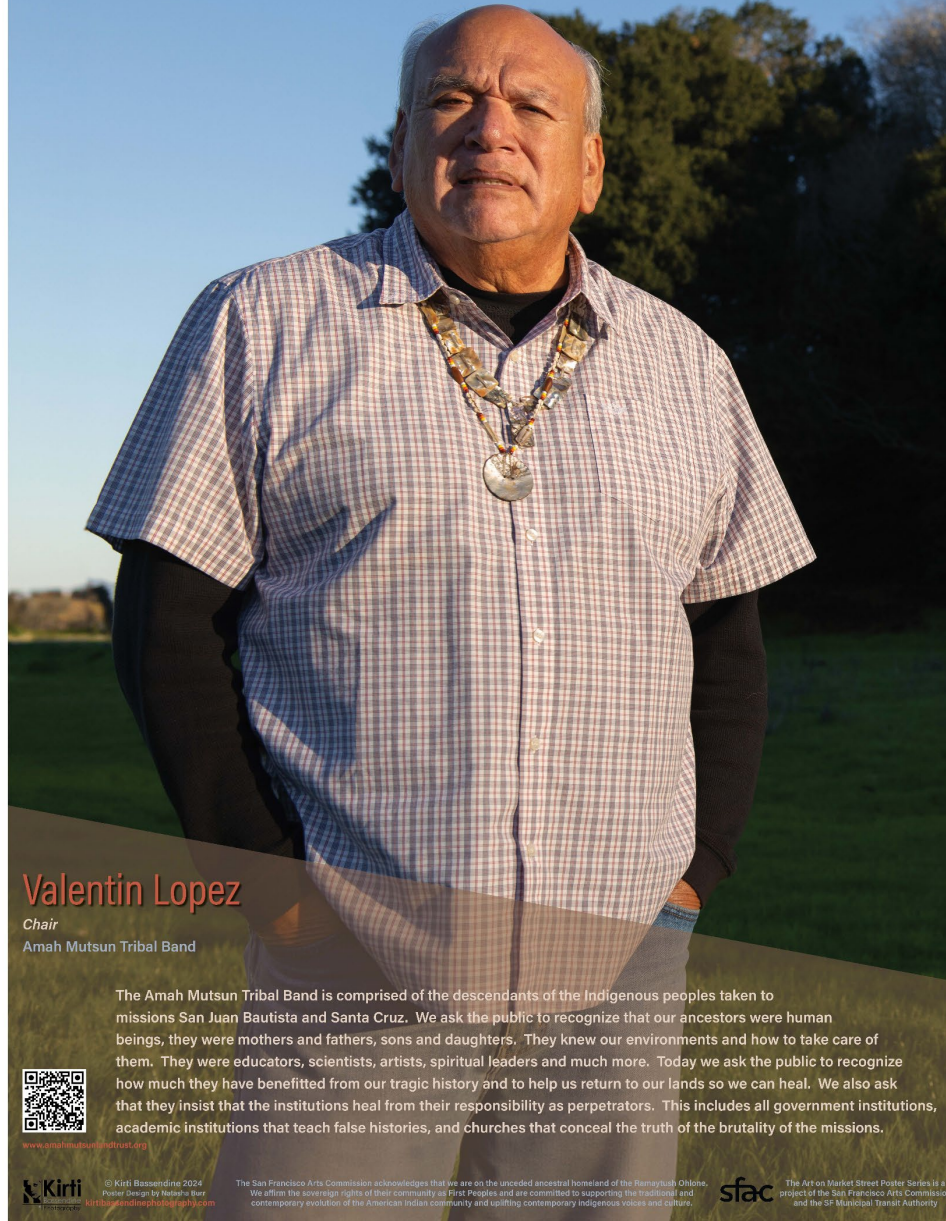

Valentin Lopez

Chair
Amah Mutsun Tribal Band

The Amah Mutsun Tribal Band is comprised of the descendants of the Indigenous peoples taken to missions San Juan Bautista and Santa Cruz. We ask the public to recognize that our ancestors were human beings, they were mothers and fathers, sons and daughters. They knew our environments and how to take care of them. They were educators, scientists, artists, spiritual leaders and much more. Today we ask the public to recognize how much they have benefitted from our tragic history and to help us return to our lands so we can heal. We also ask that they insist that the institutions heal from their responsibility as perpetrators. This includes all government institutions, academic institutions that teach false histories, and churches that conceal the truth of the brutality of the missions.



www.amahmutsuntribeband.org

© Kirti Bassendine 2024
Poster design by Helena Bee
kirti.com
www.amahmutsuntribeband.org

The San Francisco Arts Commission acknowledges that we are on the unceded ancestral homeland of the Ramaynuh Ohlone. We affirm the sovereign rights of that community as First Peoples and are committed to supporting the traditional and contemporary evolution of the American Indian community and uplifting contemporary Indigenous voices and culture.



The Art on Market Street Poster Series is a project of the San Francisco Arts Commission and the SF Municipal Transit Authority

we are still here



Linda Yamane

Master Ohlone Basket Weaver
Rumsen Ohlone Tribal Community

The Rumsen Ohlone Tribal Community is active and centered in our Carmel Valley/ Monterey area indigenous homeland. We have more than 300 members representing several documented Rumsen Ohlone lineages, though many live outside the Monterey Bay region.



www.RumsenOhlone.com

Our ongoing goal is to reach out to others who trace their ancestry to Rumsen speaking people indigenous to the Monterey area. Our community was traumatized and fractured, traditions lost. But now we have brought ourselves together again to share our history and culture, such as Rumsen language, traditional basketry, songs, plant uses, old-time stories, dance and regalia.



© Kiri Bassen/2024
Photo: Design by Heidi's Post
kiri.bassenandphotography.com

The San Francisco Arts Commission acknowledges that we are on the unceded ancestral homeland of the Ramaytush Ohlone. We affirm the sovereign rights of their community as Kiri Peoples and are committed to supporting the traditional and contemporary evolution of the American Indian community and uplifting contemporary indigenous voices and culture.



The Art on Market Street Poster Series is a project of the San Francisco Arts Commission and the SF Municipal Transit Authority

we are still here



Tom Little Bear Nason

Tribal Chairman and President
Esselen Tribe of Monterey County

For over 6,000 years, the Esselen Tribe has steadfastly maintained a deep connection to the Santa Lucia Mountains, Carmel Valley, and Big Sur. Through landmark Landback deals, we've reclaimed ancestral lands lost for 250 years, marking a revival of our rich culture and spirituality in solitude. This reclamation also fosters unity and healing, as we share this victory with other indigenous communities. With a vow of never leaving our sacred grounds again, we, the Esselen, are ensuring our legacy and traditions continue to thrive.



www.esselentribe.org

 © Kirti Bassendine 2024
Power Design by Melissa Bear
kirtibassendinephotography.com

The San Francisco Arts Commission acknowledges that we are on the unceded ancestral homeland of the Ramayush Ohlone. We affirm the sovereign rights of their community as First Peoples and are committed to supporting the traditional and contemporary evolution of the American Indian community and uplifting contemporary indigenous voices and culture.



The Art on Market Street Poster Series is a project of the San Francisco Arts Commission and the SF Municipal Transit Authority

we are still here

Mary Rodgers

Traditional Lead

Salinan Tribe of San Luis Obispo and Monterey Counties

Since time immemorial, the Salinan people have known the San Antonio Valley and its surroundings as home, stretching from Carmel Valley to Morro Bay, and from Big Sur to the Gabilan Mountains. Despite enduring hardships like the American Genocide, we persist, striving to revive our culture and language. Our roots run deep in this land, and we remain steadfast, demonstrating our profound connection to it. We're not just surviving; we're here to thrive, embodying the resilience of our people and our enduring bond with our homeland.



www.salinantribe.com



© Kiri Bassendine 2024
Poster Design by Helena Tam
<http://www.helenaart.com>

The San Francisco Arts Commission acknowledges that we are on the unceded ancestral homeland of the Ramaytush Ohlone. We affirm the sovereign rights of their community as First Peoples and are committed to supporting the traditional and contemporary evolution of the American Indian community and uplifting contemporary Indigenous voices and culture.



The Art on Market Street Poster Series is a project of the San Francisco Arts Commission and the SF Municipal Transit Authority

we are still here

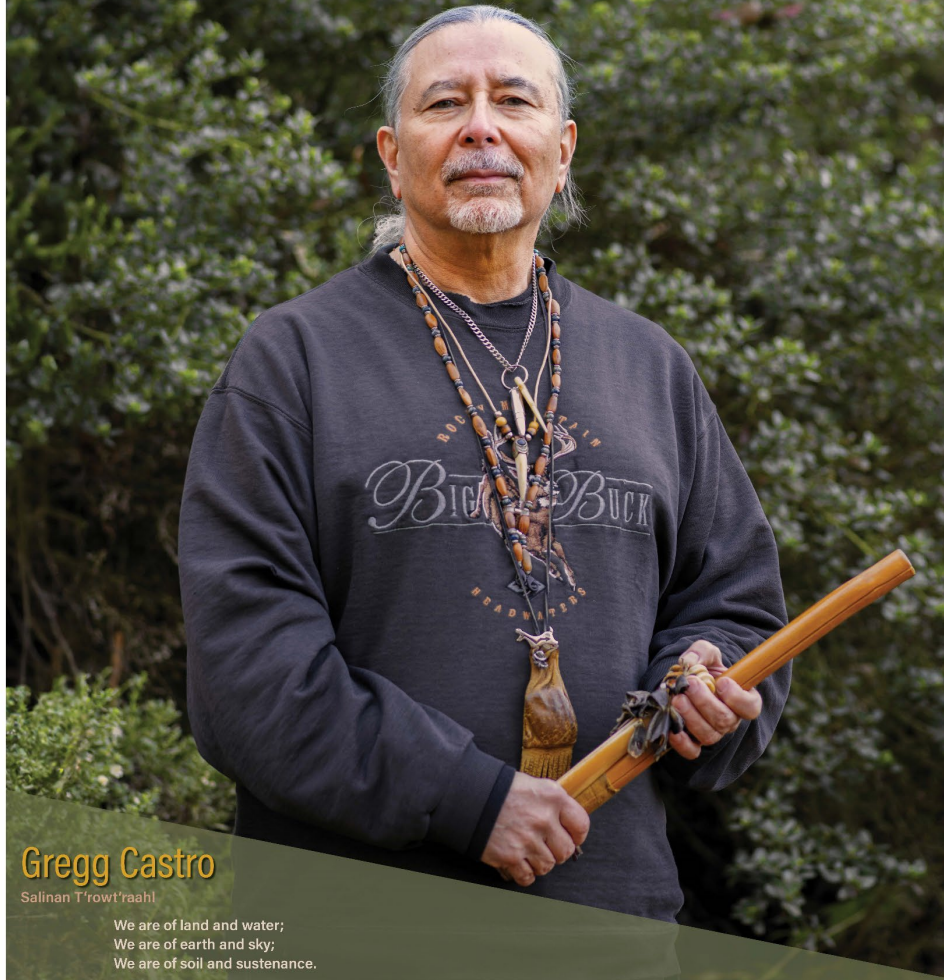

Gregg Castro

Salinan T'rowt'raahl

We are of land and water;
We are of earth and sky;
We are of soil and sustenance.

We are not from the land, we are **of** the land, and the land is of us.

There are those of us still blessed with this understanding;
For some, that memory has been suppressed by violence and genocide;
For others it is like a distant, faint dream that illuminates the horizon afar.

But Elders, Ancestors and Narratives remind us it is still there, and it waits for us.



© Kirti Bassendine 2024
Poster Design by Heavens Eye
kirtibassendinephotography.com

The San Francisco Arts Commission acknowledges that we are on the unceded ancestral homeland of the Ramaynuh Ohlone.
We affirm the sovereign rights of their community as First Peoples and are committed to supporting the traditional and contemporary evolution of the American Indian community and uplifting contemporary Indigenous voices and culture.



The Art on Market Street Poster Series is a project of the San Francisco Arts Commission and the SF Municipal Transit Authority



Public Comment

Item 5: 2024 Art on Market Street Poster Series

Item 5: 2024 Art on Market Street Poster Series

Action

Motion to approve the 10 final designs by Kirti Bassendine for the 2024 Art on Market Street Poster Series.

Item 6: Mission Bay School Public Art Project

Discussion and Possible Action

Presenter: Project Manager Arianne G. Davidian

Presentation Time: Approximately 7 minutes

Discussion and possible action to approve finalists Harumo Sato, Priscila De Carvalho, Josue Rojas, and Nico Berry to create conceptual proposals for the Mission Bay School Public Art Project, as recommended by the artist review panel.

MISSION BAY SCHOOL

ARTIST REVIEW PANEL ONE:
FINALISTS



VAC May 15, 2024

sfac

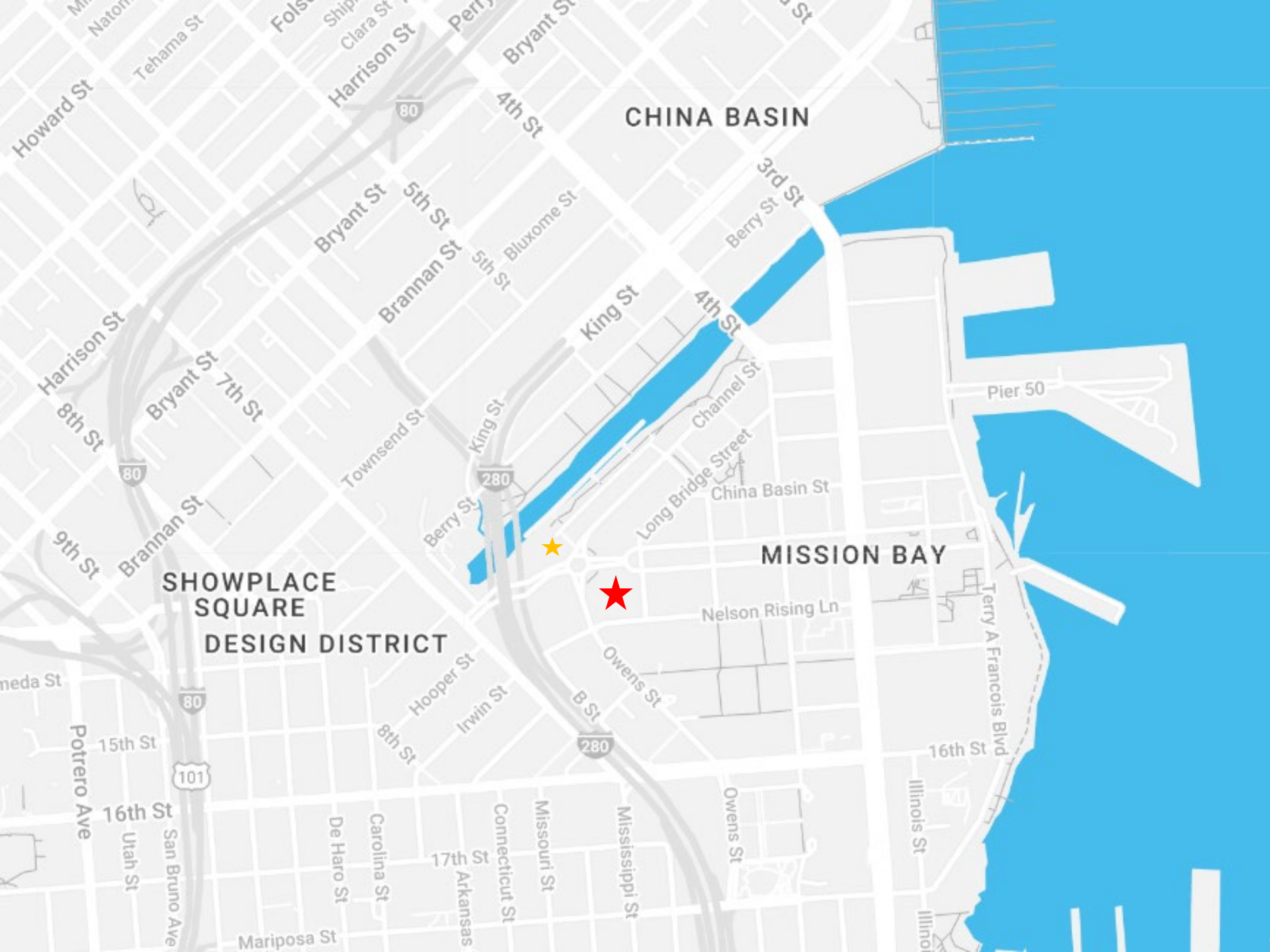

CHINA BASIN

MISSION BAY

SHOWPLACE
SQUARE
DESIGN DISTRICT







MISSION BAY SCHOOL

ARTIST REVIEW PANEL 1 – April 30, 2024

- Reviewed a shortlist of **15** applicants for the Mission Bay School Public Art Project.
- Panel has identified **4** finalists to recommend for Arts Commission approval to develop conceptual proposals for the Mission Bay School Public Art Project.



**MISSION BAY SCHOOL
ARTIST REVIEW PANEL ONE SUMMARY**

MEETING DATE

April 30, 2024

VOTING SELECTION PANELISTS

Michael Arcega, Artist; Associate Professor, San Francisco State University

Demetri Broxton, Artist, Senior Director of Education, MoAD

Sarah Davis, Community Representative

Dakota Devos, Public Art Professional

Tiffany Gong, Project Manager, SFUSD

Licinia Iberri, Bond Program Director, SFUSD

Bolívar Puyol, Project Architect, DLR Group

PROCESS

Arts Commission staff presented the qualifications of 15 artists selected from CDD 2000 Marin Street Qualification Panel. The Artist Selection Panel discussed the qualifications of these artists and scored each artist on the following criteria (1= low score):

- Artistic Merit (1-10)
- Relevant Skills and Experience (1-5)
- Meeting the Project Goals and Goals of the Civic Art Collection (1-5)

Voting yielded 4 finalists who will create conceptual proposals for the Mission Bay School Public Art Project.

RESULTS

Harumo Sato	129
Priscila De Carvalho	117
Josue Rojas	117
Nico Berry	115



HARUMO SATO



HARUMO SATO





PRISCILA DE CARVALHO



PRISCILA DE CARVALHO



JOSUE ROJAS



JOSUE ROJAS



NICO BERRY

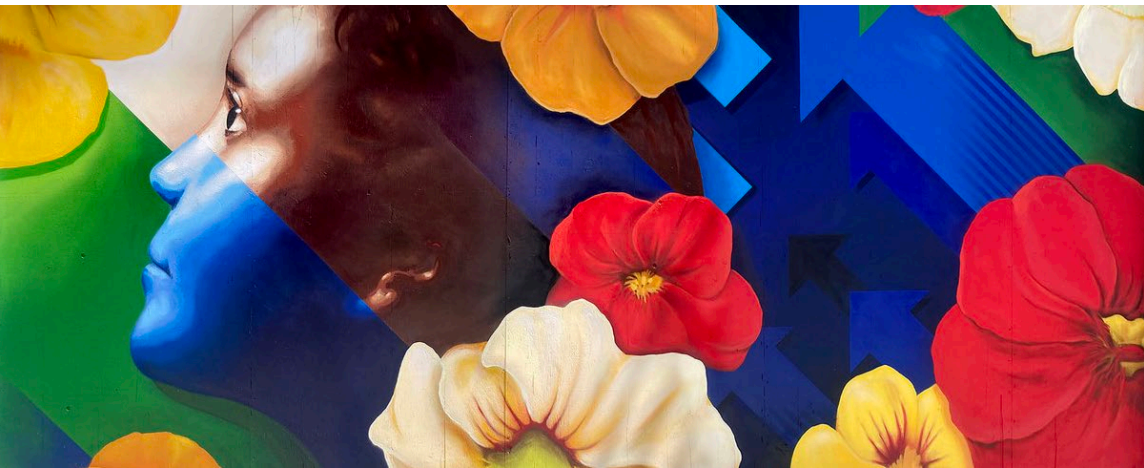

NICO BERRY

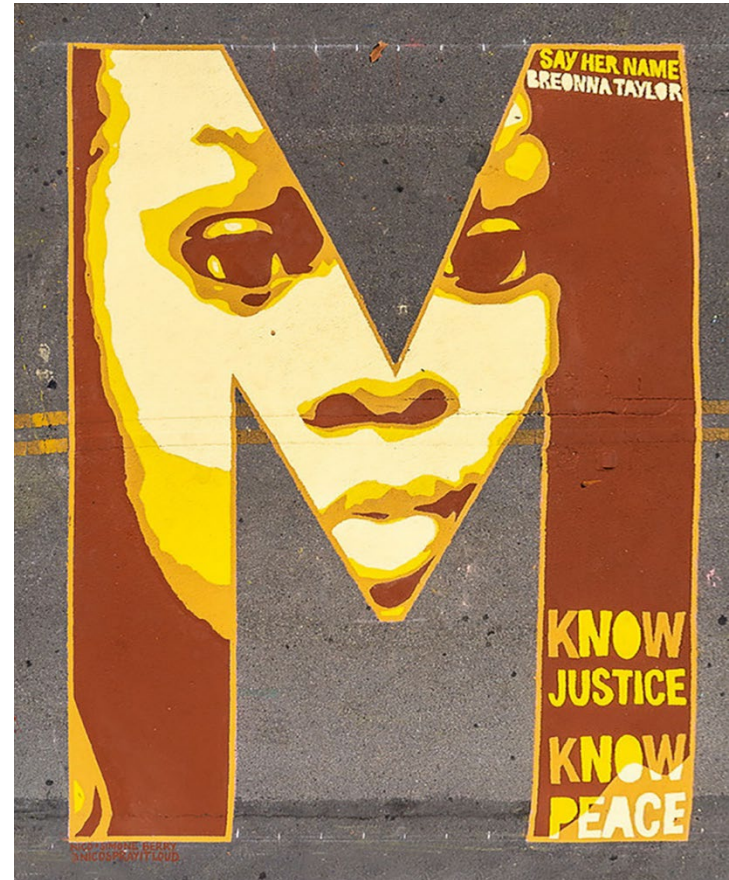



HARUMO SATO



PRISCILA DE CARVALHO



JOSUE ROJAS



NICO BERRY

PROJECT TIMELINE

Artist Review Panel 1	April 30
VAC Approves Finalists	May 15
Artist Orientation	Week of May 20
Finalist Proposals Due	July 10
Public Comment	July 12-26
Final Project Artist Review Panel	Week of August 5
Commission Approvals	August - September
Artist Under Contract	October 2024
School Opens!	August 2025

BUDGET

Total Art Enrichment Amount \$250,000

Artist Contract Budget \$136,000

Inclusive of all artist's fees, as well as associated expenses for artwork design, fabrication, insurance, transportation, and installation.

Public Comment

Item 6: Mission Bay School Public Art Project

Item 6: Mission Bay School Public Art Project

Action

Motion to approve finalists Harumo Sato, Priscila De Carvalho, Josue Rojas, and Nico Berry to create conceptual proposals for the Mission Bay School Public Art Project, as recommended by the artist review panel.

Item 7: Gene Friend Recreation Center Project

Discussion and Possible Action

Presenter: Project Manager Arianne G. Davidian

Presentation Time: Approximately 10 minutes

Discussion and possible action to approve the conceptual design proposal *Barrio Fiesta* by Cristina Carpio for the Gene Friend Recreation Center Integrated Wall Artwork, as recommended by the artist review panel.

Discussion and possible action to authorize the Director of Cultural Affairs to enter into a contract with Cristina Carpio for an amount not to exceed \$206,550 for the design, engineering, fabrication, transportation, and installation consultation of an Integrated Wall Artwork for the Gene Friend Recreation Center Project.



Barrio Fiesta

CECE CARPIO

APRIL 17, 2024
VISUAL ARTS COMMITTEE MEETING

sfac



Barrio Fiesta

Cece Carpio

Art Proposal for the Gene Friend Recreation Center

Barrio Fiesta translates to a neighborhood celebration bringing communities together where everyone is welcome as guests and active participants. San Francisco's SOMA district was one of my first stomping grounds after migrating to the United States at twelve years old. My experience of SOMA through the decades is remarkably similar to a *Barrio Fiesta*, allowing me to explore all aspects of convergence. Personally rooted in my culture and the Bay Area, I understand this design opportunity is part storytelling and part building décor- a signature amenity that puts Gene Friend Recreation Center and *Barrio Fiesta* on the map.

This design intertwines historical, present-day, and futuristic figures to capture the vision and spirit of the SOMA neighborhood. It includes everyday people enacting evolved traditions and cultural practices celebrating the vibrancy of the SOMA district. It weaves together recognizable faces- well-known individuals, suggested by Gene Friend stakeholders -along with representations of veterans, elders, youth, Indigenous migrants, community builders, and advocates to showcase the diversity and vitality of the SOMA community. Some of the portraits depicted will change based on interviews that will be conducted with SF SOMA Community members for a more in-depth community engagement process.

The artwork's background colors are inspired by pre-colonial textiles from various regions in the Philippines. Motif designs within the end pillars that are also integrated throughout the layout are rendered patterns found in textiles and wood carvings. Due to the architectural size and design of the building, this artwork design intends to fully utilize all available space for maximum impact and visibility. A rendered Gene Friend building is inserted in the background to reflect and converge the lively activities that happen inside and outside of the center.



Previous work sample and close-up painting style example

View of gym from 6th and Folsom Streets



Philippine textile inspirations

Contemporary Barrio Fiesta at SF SOMA district: Undiscovered SF



View of artwork on north-facing wall of gym



GENE FRIEND RECREATION CENTER PROJECT

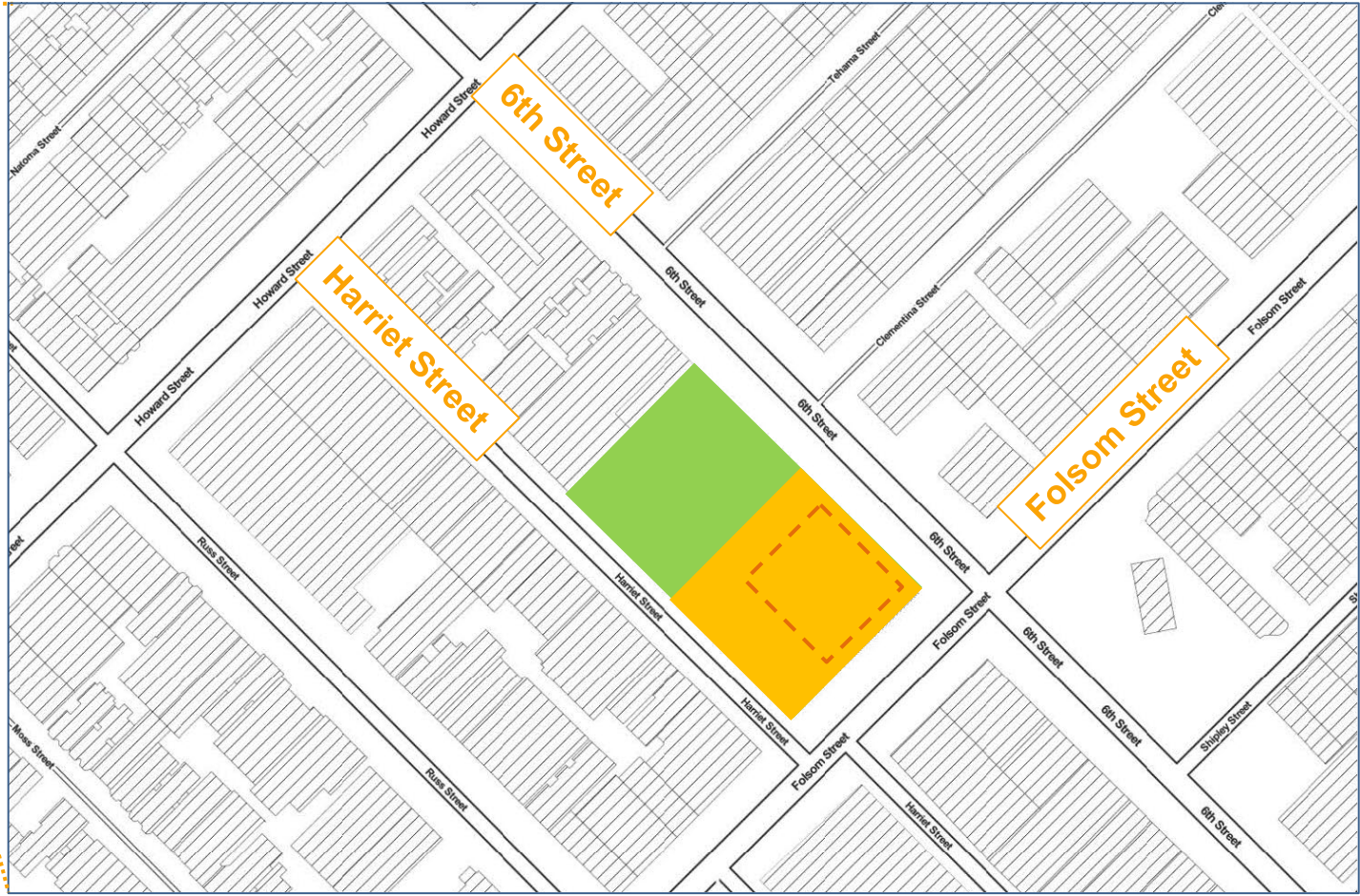

GENE FRIEND RECREATION CENTER PROJECT

1. ENTRANCE AT HARRIET STREET



INVITING ENTRY ON HARRIET STREET
MARK CAVAGNERO ASSOCIATES | KUTH RANIERI ARCHITECTS - GENE FRIEND RECREATION CENTER

3. ARCHITECTURAL SCREEN - CONCEPT DIAGRAM

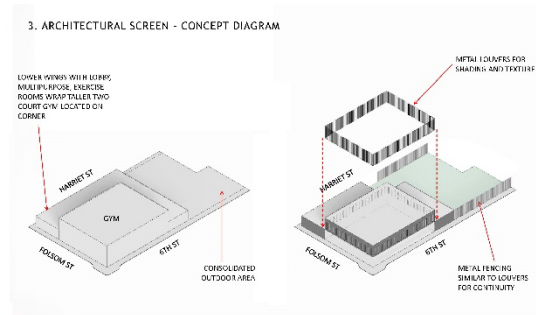

MARK CAVAGNERO ASSOCIATES | KUTH RANIERI ARCHITECTS - GENE FRIEND RECREATION CENTER



CORNER 6TH AND FOLSOM - DAY

MARK CAVAGNERO ASSOCIATES | KUTH RANIERI ARCHITECTS - GENE FRIEND RECREATION CENTER



STREET VIEW AT FOLSOM & 6TH STREET (LOW POINT)

MARK CAVAGNERO ASSOCIATES | KUTH RANIERI ARCHITECTS - GENE FRIEND RECREATION CENTER



GENE FRIEND RECREATION CENTER PROJECT

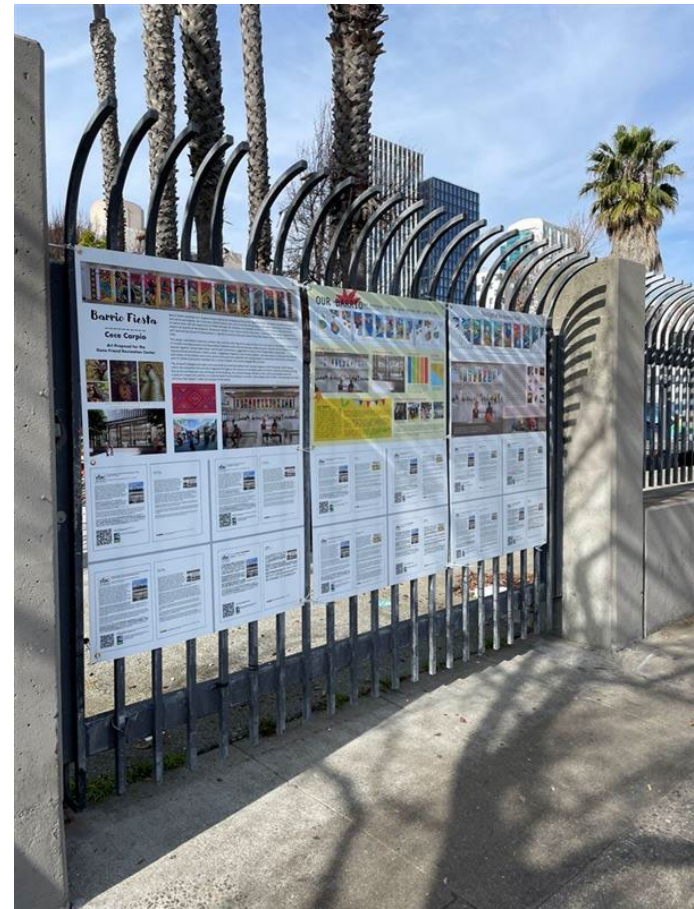



GENE FRIEND RECREATION CENTER – INTEGRATED WALL ARTWORK ARTIST REVIEW PANEL TWO SUMMARY

MEETING DATE

March 13, 2024

VOTING SELECTION PANELISTS

Erina Alejo, Artist, Cultural Worker + Arts Administrator

Renee Villasenor, Programs Manager and Curatorial Associate, ICA SF

Jena McRae Schwartz, Managing Director, SOMArts Cultural Center

Vanessa Bis, Program Manager, United Playaz

Nabiel Musleh, Arts Commissioner, SFAC

Melinda Sullivan, Project Manager, Capital & Planning Division, SF Recreation and Parks

Eliza Koshland, Senior Associate Kuth Ranieri Architects (shared vote)

Kurt Stubbins, Senior Designer, Mark Cavagnero Associates Architects (shared vote)

PROCESS

Three artist finalists presented their proposals for the Gene Friend Recreation Center Integrated Wall Artwork Public Art Project. The Artist Review Panel discussed the finalists' proposals and scored each artist on the following criteria (1= low score):

Artistic Merit (1-10)

Meets Project Goals (1-10)

Meaningful Connection to SOMA neighborhood (1- 10)

Appropriate to Site (1-5)

RESULTS

Cece Carpio 239

ChiChai Mateo 207

Adrian Arias 185

ARTS COMMISSION APPROVAL

Discussion and possible action to approve the conceptual design proposal *Barrio Fiesta* by Cece Carpio for the Gene Friend Recreation Center Integrated Wall Artwork, as recommended by the artist review panel.

Discussion and possible action to authorize the Director of Cultural Affairs to enter into a contract with Cece Carpio for an amount not to exceed \$206,550 for the design, engineering, fabrication, transportation, and installation consultation of an Integrated Wall Artwork for the Gene Friend Recreation Center Project.





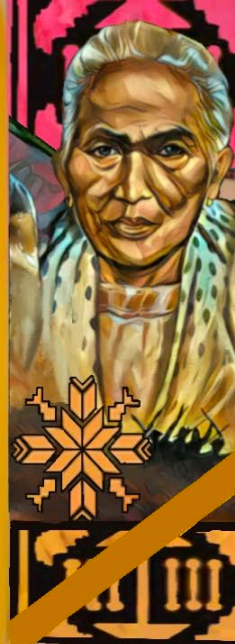
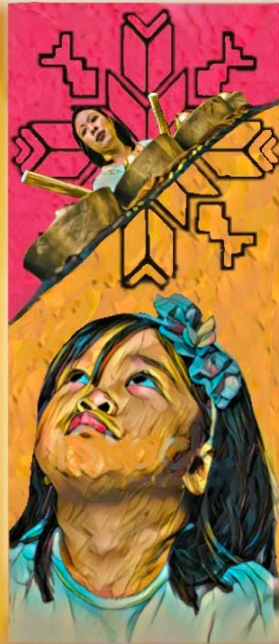

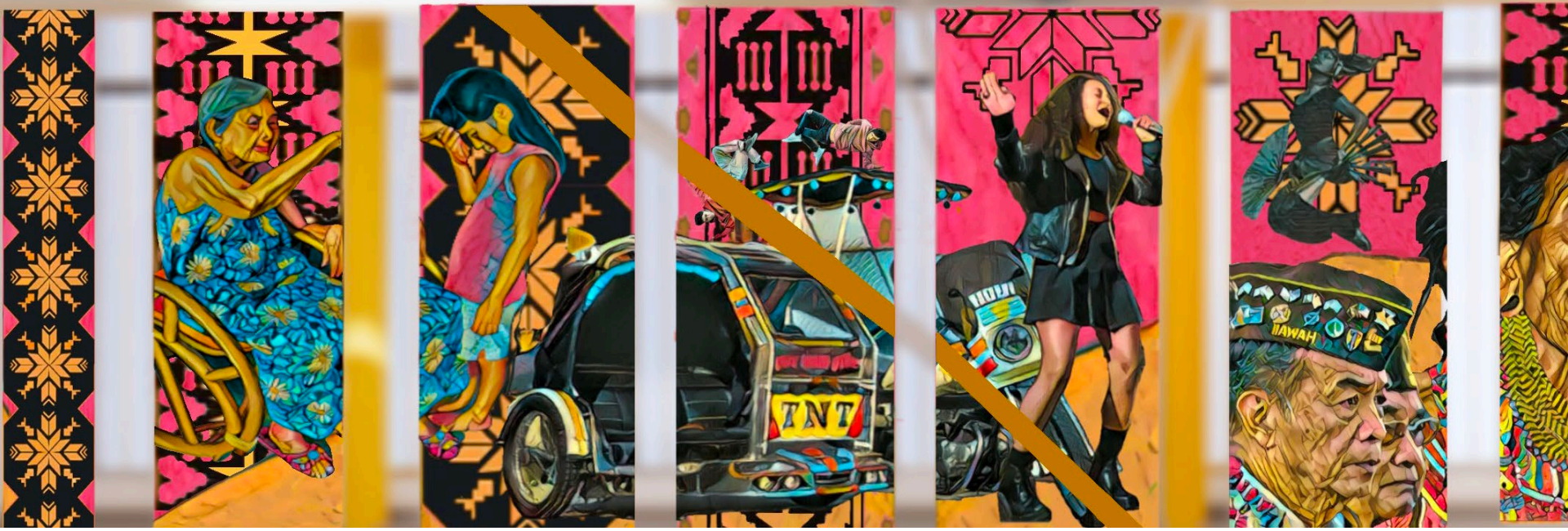

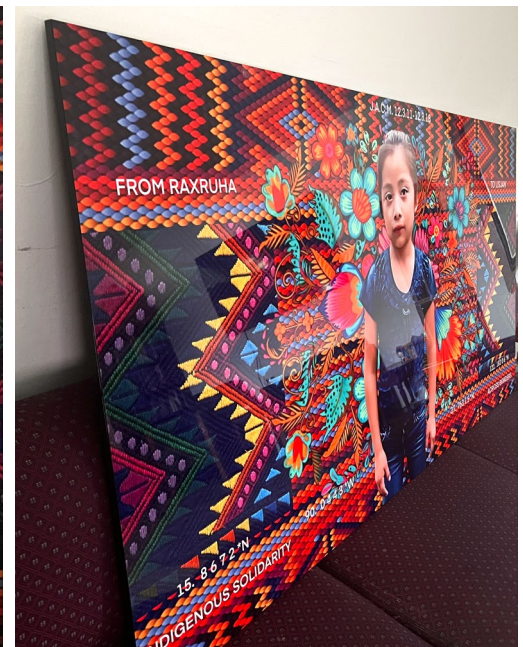

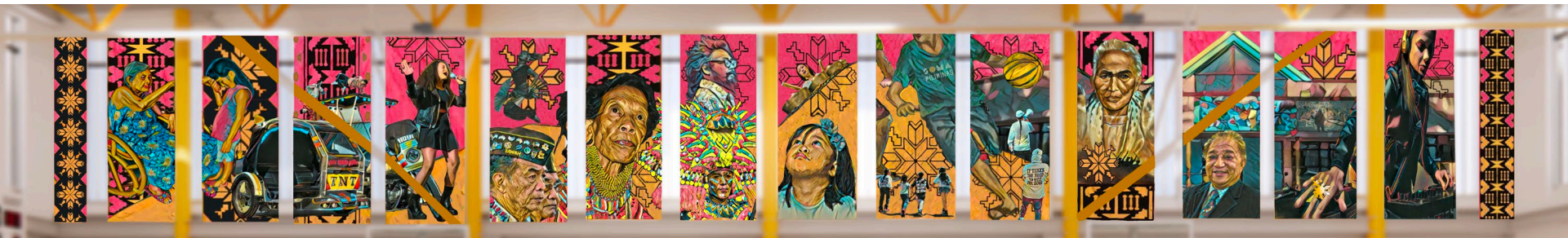

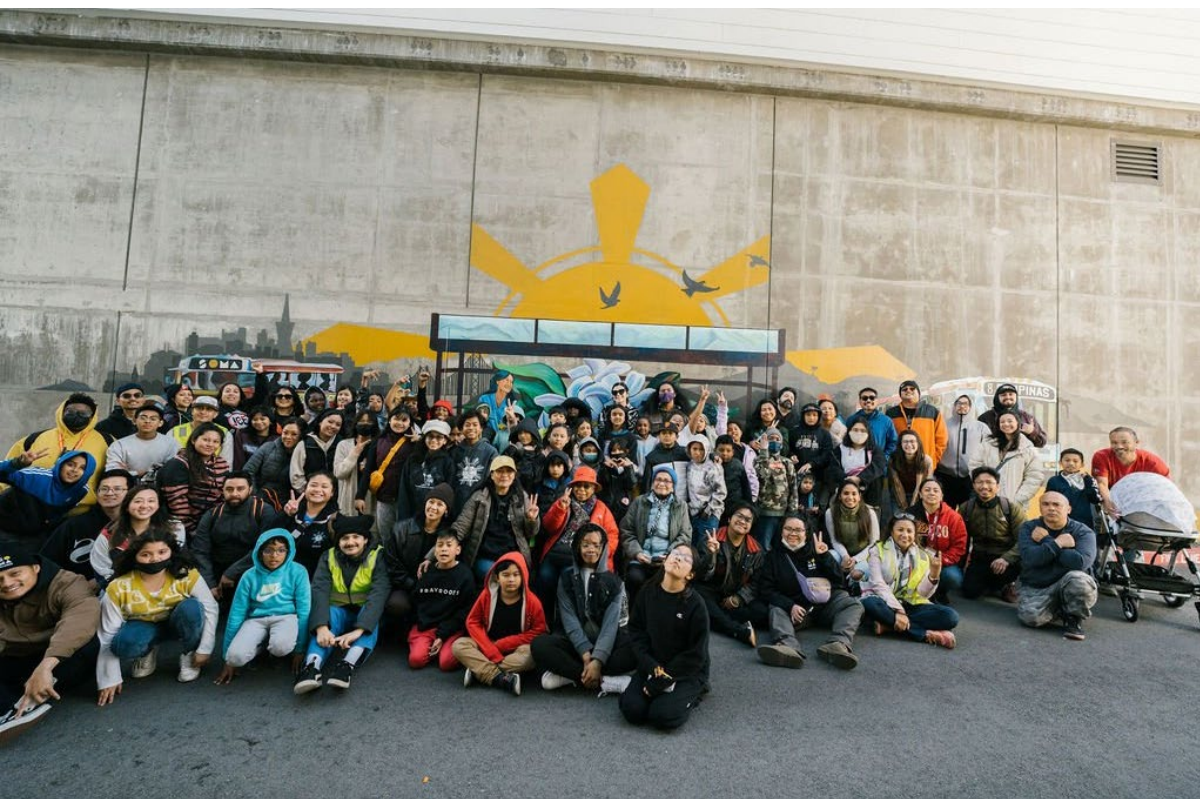
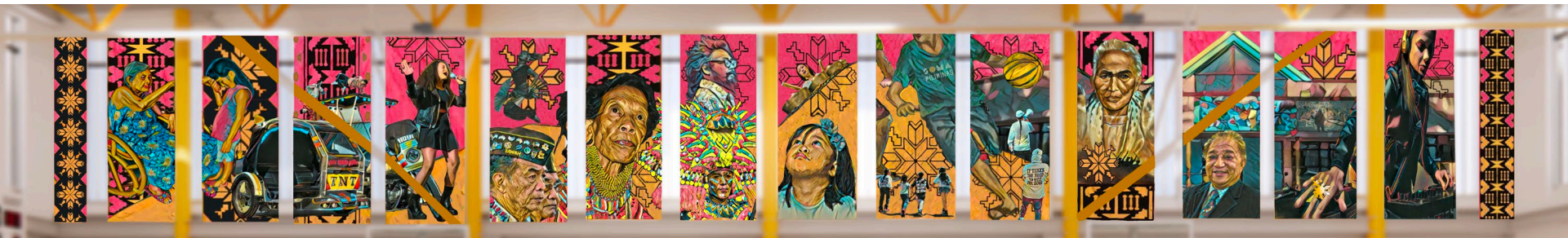



Barrio Fiesta

Cece Carpio

Art Proposal for the Gene Friend Recreation Center

Barrio Fiesta translates to a neighborhood celebration bringing communities together where everyone is welcome as guests and active participants. San Francisco's SOMA district was one of my first stomping grounds after migrating to the United States at twelve years old. My experience of SOMA through the decades is remarkably similar to a *Barrio Fiesta*, allowing me to explore all aspects of convergence. Personally rooted in my culture and the Bay Area, I understand this design opportunity is part storytelling and part building décor- a signature amenity that puts Gene Friend Recreation Center and *Barrio Fiesta* on the map.

This design intertwines historical, present-day, and futuristic figures to capture the vision and spirit of the SOMA neighborhood. It includes everyday people enacting evolved traditions and cultural practices celebrating the vibrancy of the SOMA district. It weaves together recognizable faces- well-known individuals, suggested by Gene Friend stakeholders -along with representations of veterans, elders, youth, Indigenous migrants, community builders, and advocates to showcase the diversity and vitality of the SOMA community. Some of the portraits depicted will change based on interviews that will be conducted with SF SOMA Community members for a more in-depth community engagement process.

The artwork's background colors are inspired by pre-colonial textiles from various regions in the Philippines. Motif designs within the end pillars that are also integrated throughout the layout are rendered patterns found in textiles and wood carvings. Due to the architectural size and design of the building, this artwork design intends to fully utilize all available space for maximum impact and visibility. A rendered Gene Friend building is inserted in the background to reflect and converge the lively activities that happen inside and outside of the center.



Previous work sample and close-up painting style example

View of gym from 6th and Folsom Streets



Philippine textile inspirations

Contemporary Barrio Fiesta at SF SOMA district: Undiscovered SF



View of artwork on north-facing wall of gym



Public Comment

Item 7: Gene Friend Recreation Center Project

Item 7: Gene Friend Recreation Center Project

Action

Motion to approve the conceptual design proposal *Barrio Fiesta* by Cristina Carpio for the Gene Friend Recreation Center Integrated Wall Artwork, as recommended by the artist review panel.

Motion to authorize the Director of Cultural Affairs to enter into a contract with Cristina Carpio for an amount not to exceed \$206,550 for the design, engineering, fabrication, transportation, and installation consultation of an Integrated Wall Artwork for the Gene Friend Recreation Center Project.

Item 8: San Francisco International Airport Terminal 3 Connector Two-Dimensional Artwork Program

Discussion and Possible Action

Presenter: Project Manager Arianne G. Davidian

Presentation Time: Approximately 10 minutes

Discussion and possible action to approve the list of two-dimensional artworks for purchase and display at SFO Terminal 3 Connector corridor wall niches:

- Keisha Scarville, Li/mb, 2024, diptych, Archival inkjet print, H24 in. x W72 in., \$6,000
- Eve Sandler, Cornucopia (with Okra Pods), 2023, Synthetic hair, metal earring, okra, cowrie shell, H40 in. x W8 in. x D2 in., \$9,500
- Kenyatta A.C. Hinkle, The Wig, 2014, Collage on Polyfilm, H11 in. x W8.5 in., \$8,082.05.
- Sydney Cain, Black Flight, 2019, lithograph, edition 6 of 6, H19 in. x W15 in., \$1,500
- yétúndé ọlágbajú, Our shared horizons #1 - #95, 2022, Photo transfer on travertine stone, Dimensions variable, \$9,000 (Set of up to 30 to be selected from the 95 in the series)
- Erica Deeman, Journey To An Illusion, 2023, Photography, H30 in. x W24 in., \$12,500
- Taller Sanaa (Jessica Sabogal and Shanna Strauss), Serpiente de las Estrellas, 2021, Photopolymer gravure, silkscreen, and gold leaf with chine-collé, H30 in. x W22 in., edition of 2, \$9,000
- Trina Robinson, Crown, 2023, Photogravure, chine collé, handmade palm paper, H14 in. x W11 in., \$8,000
- Myra Greene, To Tailor a Pattern: O1, 2022, Hand dyed and silkscreened textile, H32 in. x W35 in., \$9,500
- Adama Delphine Fawundu, For the Ancestors at Malaga Island #11, #2, #4, #7, #9, #8 (Set of 6), 2023, Monoprint on Silver Gelatin, H16 in. x W12 in. each, \$12,000
- Adia Millet, Integrity (Portal), 2023, Acrylic on panel, H36 in. x W36 in., \$20,000



SFO TERMINAL 3 CONNECTOR

TWO-DIMENSIONAL ARTWORK PROGRAM ARTWORKS

Visual Arts Committee – May 15, 2024

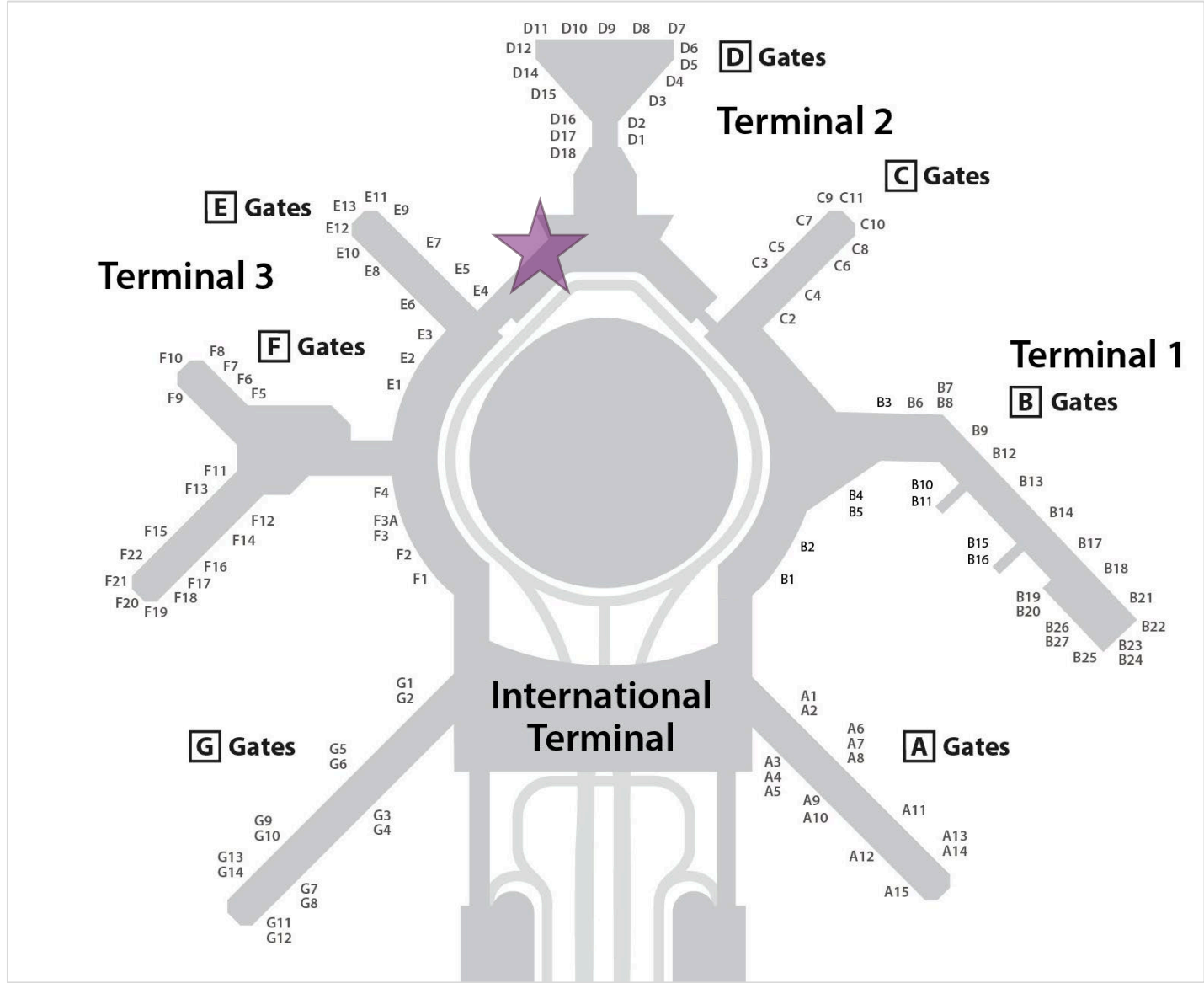

POST-SECURITY CONNECTOR
OVERALL PLAN

- POST-SECURITY CONNECTOR
- PRE-SECURITY CONNECTOR
- KADISH GALLERY
- BUILDING LOBBY ENTRANCE
- CONCESSIONS
- OFFICE BUILDING FOOTPRINT

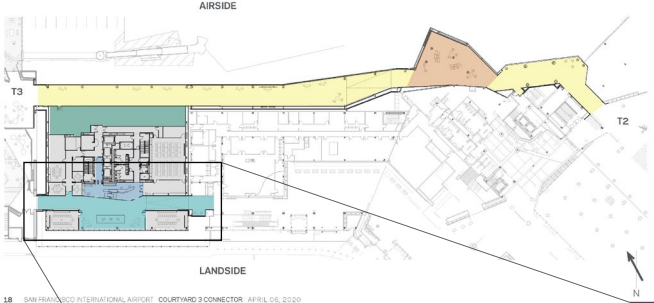

18 SAN FRANCISCO INTERNATIONAL AIRPORT COURTYARD 9 CONNECTOR APRIL 06 2020

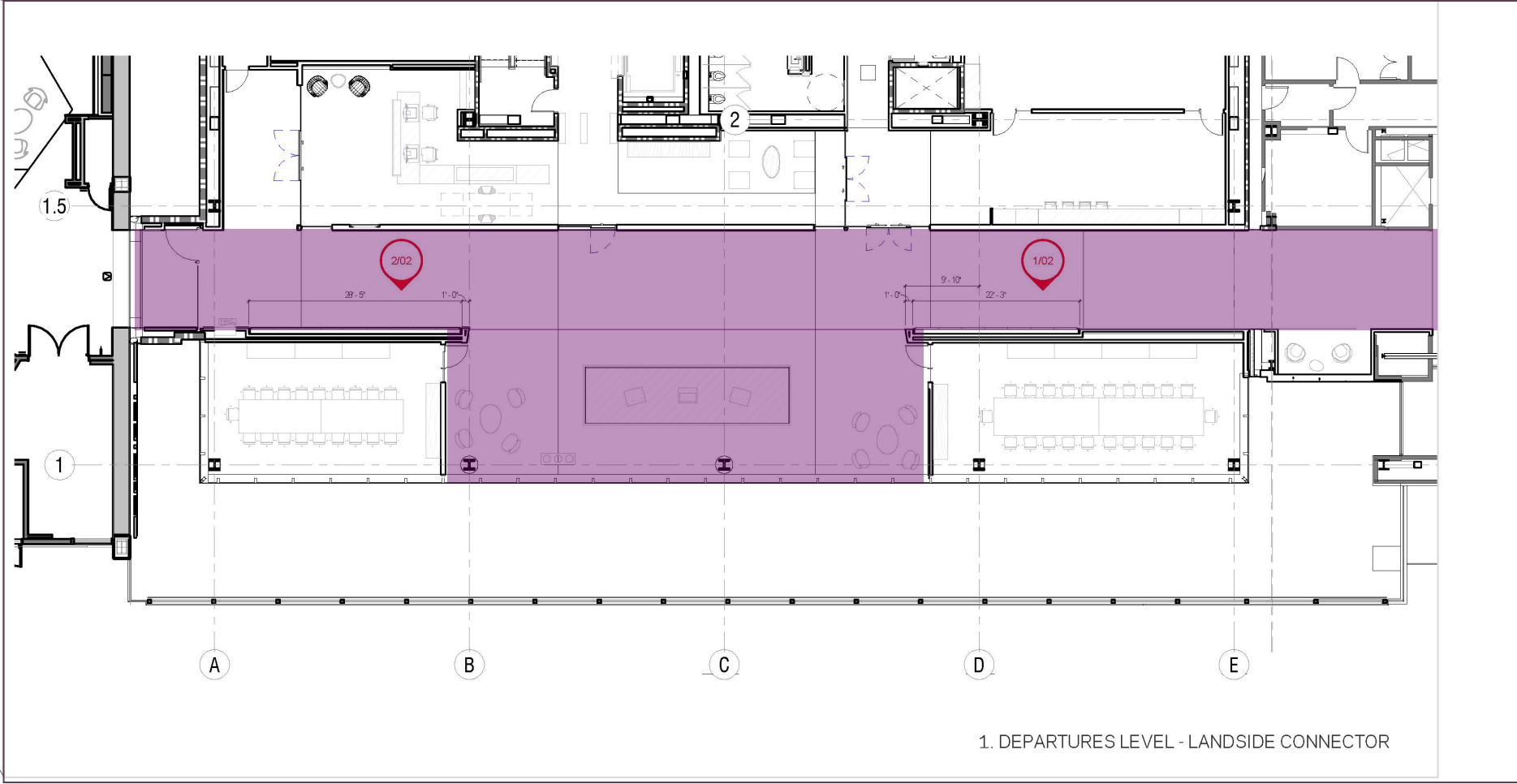

1. DEPARTURES LEVEL - LANDSIDE CONNECTOR





Alison Saar
Flourish, 2021

PROJECT GOALS

- Enrich the experience of the public corridor.
- Relate conceptually, aesthetically, and/or in an art historical context to the adjacent Saar sculpture. Possible themes may include: Immigration, diaspora, setting roots, and the process of becoming.
- Contribute to the quality and diversity of San Francisco's Civic Art Collection in its representation of artists and artistic styles.
- Provide opportunity to artists with a meaningful connection to the San Francisco Bay Area. At the same time, the purchased artworks, as a curated selection, should represent artists from greater California and the US so that local artists are seen in the context of a broader artistic dialogue.



ARTWORK SELECTION PROCESS

Curatorial Committee (August 2023)

Alison Saar

Ashara Ekundayo

Kai Caemmerer

Arianne G. Davidian

Artwork Selection Panel (March 2024)

Alison Saar

Ashara Ekundayo

Kai Caemmerer + Alisa Eagleston-Cieslewicz

Arianne G. Davidian

Jeanne McCoy



Keisha Scarville
Li/mb (Dptych)
2024
Archival inkjet print
24 x 72 inches



Eve Sandler

Cornucopia (with Okra Pods), 2023

Synthetic hair, metal earring, okra,
cowrie shell

40 x 8 x 2 inches

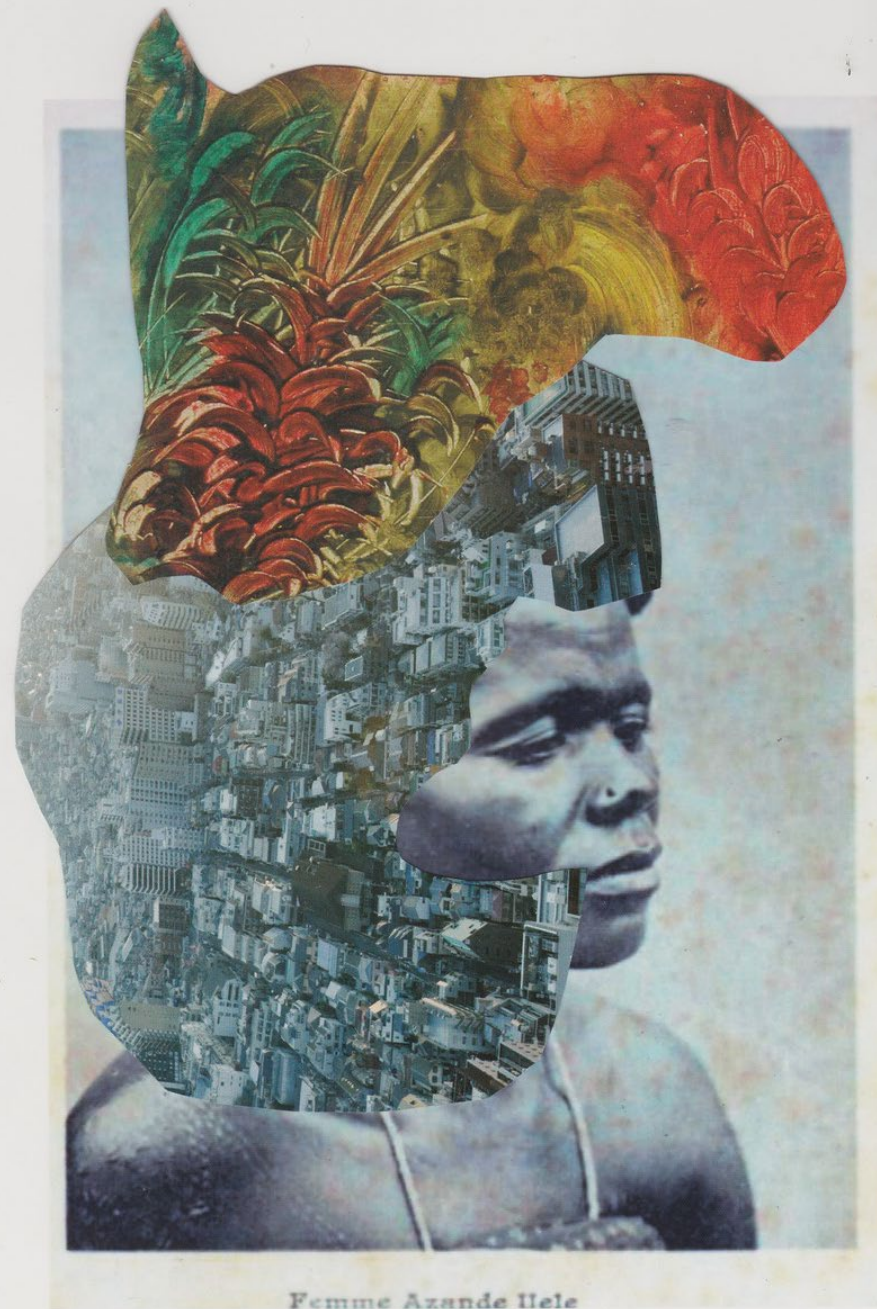

Kenyatta A.C. Hinkle
The Wig, 2014
Collage on Polyfilm
11 x 8.5 inches



Sydney Cain
Black Flight, 2019
Lithograph
Edition 6 of 6
19 x 15 inches



yétúndé ọlágбайú

Our shared horizons #1 - #95, 2022

Photo transfer on travertine stone

Dimensions Variable



Erica Deeman
Journey To An Illusion, 2023
Photography
30 x 24 inches



Jessica Sabogal + Shanna Strauss

Serpiente de las Estrellas, 2021

Photopolymer gravure, silkscreen,
and gold leaf with chine-collé

Edition of 2

30 x 22 inches



Trina Robinson

Crown, 2023

Photogravure, chine collé,
handmade palm paper

14in x 11 inches

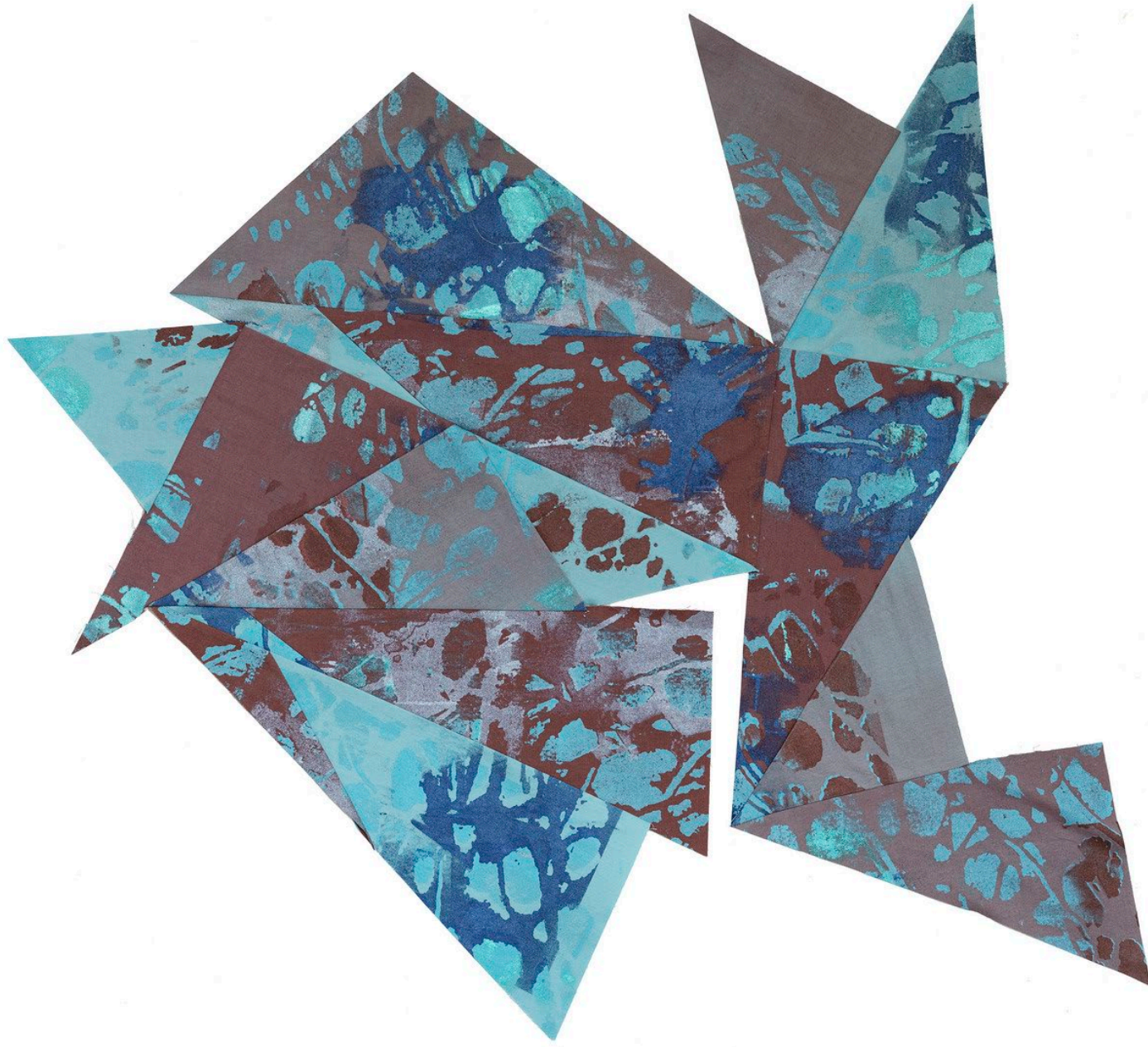

Myra Greene

To Tailor a Pattern: O1, 2022

Hand dyed and silkscreened
textile

32 by 35 inches













Adama Delphine Fawundu
For the Ancestors at Malaga Island
#11, #2, #4, #7, #9, #8 (Set of 6)
2023
Monoprint on Silver Gelatin
Each 16 x 12 inches



Adia Millet
Integrity (Portal), 2023
Acrylic on panel
36 x 36 inches

SFO Terminal 3 Connector 2D Artwork Program / Review Panel Tally
 March 7, 2024

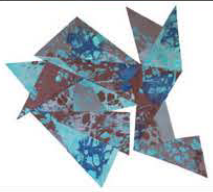
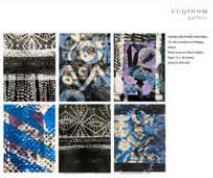
Score	First	Last	Image	Info
28	Keisha	Scarville		Keisha Scarville, Li/mb, 2024, diptych, Archival inkjet print, H24 in. x W72 in., \$6,000
29	Eve	Sandler		Eve Sandler, Cornucopia (with Okra Pods), 2023, Synthetic hair, metal earring, okra, cowrie shell, H40 in. x W8 in. x D2 in., \$9,500
	Kenyatta	A.C. Hinkle		Kenyatta A.C. Hinkle, The Wig, 2014, Collage on Polyfilm, H11 in. x W8.5 in., \$8,082.05
	Sydney	Cain		Sydney Cain, Black Flight, 2019, lithograph, edition 6 of 6, H19 in. x W15 in., \$1,500
31	yétúndé	qlágbajú		yétúndé qlágbajú, Our shared horizons #1 - #95, 2022, Photo transfer on travertine stone, Dimensions variable, \$9,000 (Set of up to 30 to be selected from the 95 in the series)
32	Erica	Deeman		Erica Deeman, Journey To An Illusion, 2023, Photography, H30 in. x W24 in., \$12,500

33	Jessica / Shanna	Sabogal / Strauss		Taller Sanaa (dba Jessica Sabogal and Shanna Strauss), Serpiente de las Estrellas, 2021, Photopolymer gravure, silkscreen, and gold leaf with chine-collé, H30 in. x W22 in., edition of 2, \$9,000
35	Trina	Robinson		Trina Robinson, Crown, 2023, Photogravure, chine collé, handmade palm paper, H14 in. x W11 in., \$8,000
37	Myra	Greene		Myra Greene, To Tailor a Pattern: O1, 2022, Hand dyed and silkscreened textile, H32 in. x W35 in., \$9,500
39	Adama Delphine	Fawundu		Adama Delphine Fawundu, For the Ancestors at Malaga Island #11, #2, #4, #7, #9, #8 (Set of 6), 2023, Monoprint on Silver Gelatin, H16 in. x W12 in. each, \$12,000
45	Adia	Millet		Adia Millet, Integrity (Portal), 2023, Acrylic on panel, H36 in. x W36 in., \$20,000

\$ 105,083

PROJECT TIMELINE

2023

Project Plan Approval (VAC)

July 19

Project Plan Approval (AASC)

August 24

Curatorial Committee Meeting #1

August 31

Artist Nominations

September 25

2024

Artists Submit Artworks Via Slideroom

February 15

Artist Review Panel Meeting

March 7

Final Selection Approval (VAC, AASC, + AC)

May

Artwork Purchases, Framing, And Installation

Fall 2024

ARTWORK OPPORTUNITY: 2D PROGRAM

Purchase 5 to 15 existing 2D artworks to be permanently installed in the Terminal 3 Connector corridor.

**Updated 08.28.23*

BUDGET

Art Enrichment Funding	\$300,000
• Administration	\$60,000 (20%)
• Conservation	\$30,000 (10%)
• Artwork Implementation	\$210,000 (70%)
○ Curatorial Committee	\$3,000
○ Photo/Signage/Field Expenses	\$4,400
○ 2D Purchases	\$115,600
○ Framing	\$56,000
○ Delivery and Installation	\$10,000
○ Internal Contingency	\$21,000



**SFO TERMINAL 3 CONNECTOR TWO-DIMENSIONAL ARTWORK PROGRAM
PUBLIC ART PROJECT PLAN**

For presentation to the Visual Arts Committee on July 19, 2023



PROJECT BACKGROUND

The Terminal 3 Connector project at San Francisco International Airport (SFO) follows the recent construction of an SFO administrative office tower between Terminals 2 and 3, and a public connector corridor between the terminals. Completed in 2021, the sculptural installation, *Flourish*, by artist Alison Saar, is located within the connector corridor. Saar intends the work to be “a beacon that welcomes new travelers to San Francisco, reminding us of our common immigrant roots, the richness that thrives from diversity, and our shared experiences.”

A new artwork opportunity has been identified in the two wall niches on either side of the Saar installation. A photographic series, *Harlem of the West*, is currently on display in the niches, featuring a selection of images by David Johnson, Jerry Stoll, and others that chronicles the 1940s and 1950s Jazz Era in the Fillmore District of San Francisco. The photographs, which are included in San Francisco’s Civic Art Collection, will be relocated to the adjacent Kadish Gallery in 2024, leaving a new opportunity for permanent 2D artwork in the wall niches.

ART OPPORTUNITY

Two-Dimensional Artwork Program: Direct purchase of 5 to 15 existing 2D artworks ranging in size from 12 to 60 inches (maximum height or width) and 3 inches (maximum depth) for two wall niches located in the Terminal 3 Connector corridor. The visible areas within the niches are approximately 22' x 8' and 28' x 8' inset 5" and protected with secure glass panels with seams every 36 to 41 inches.

PROJECT GOALS

- Enrich the experience of the public corridor.
- Relate conceptually, aesthetically, and/or in an art historical context to the adjacent Saar sculpture. Possible themes may include: Immigration, diaspora, setting roots, and the process of becoming.
- Contribute to the quality and diversity of San Francisco's Civic Art Collection in its representation of artists and artistic styles.
- Provide opportunity to artists with a meaningful connection to the San Francisco Bay Area. At the same time, the purchased artworks, as a curated selection, should represent artists from greater California and the US so that local artists are seen in the context of a broader artistic dialogue.

ARTIST RECRUITMENT APPROACH AND ELIGIBILITY; SELECTION PROCESS

Given the location of these wall niches in proximity to the Saar sculpture and the curatorial emphasis on these selections, the following process will be used for artwork selection:

SFAC staff will form an SFO T3 Connector 2D Artwork Program Curatorial Committee consisting of two (2) arts professionals, one (1) SFO Museum Program staff, and (1) SFAC staff. The Committee will convene to develop a shortlist of up to 20 artists whose art practices align with project goals. Arts Commissioners and SFAC staff may also make recommendations.

Shortlisted artists will be invited to submit available artwork for consideration for purchase via Slideroom. A selection panel—comprised of two (2) arts professionals, one (1) Arts Commissioner, and one (1) client representative—will identify the final selection of artworks for purchase, which SFAC staff will bring to VAC, Arts Commission, Airport Art Steering Committee, and Airport Commission for approval prior to implementation.

ARTWORK BUDGET

Total Artwork Budget: \$210,000

- Curatorial Committee honoraria: \$3,000
- 2D Purchases: \$115,600
- Framing: \$77,000
- Delivery and Installation: \$10,000

TIMELINE (Subject to change)

Project Plan Approval (AASC)	July 2023
Project Plan Approval (VAC)	July 19
Curatorial Committee creates artist shortlist	Aug – Sep
Slideroom submissions of available artworks due	November
Panel identifies final selection of artworks	December
Final Selection Approval (VAC, AASC, and Airport Commission)	January 2024
Artwork Purchases, Framing, and Installation	February

FURTHER INFORMATION

Contact Arianne Gelardin Davidian, Public Art Project Manager at (415) 310-8012 or by email at arianne.gelardin@sfgov.org.

Public Comment

**Item 8: San Francisco International Airport Terminal 3
Connector Two-Dimensional Artwork Program**

Item 8: San Francisco International Airport Terminal 3 Connector Two-Dimensional Artwork Program

Action

Motion to to approve the list of two-dimensional artworks for purchase and display at SFO Terminal 3 Connector corridor wall niches:

- Keisha Scarville, Li/mb, 2024, diptych, Archival inkjet print, H24 in. x W72 in., \$6,000
- Eve Sandler, Cornucopia (with Okra Pods), 2023, Synthetic hair, metal earring, okra, cowrie shell, H40 in. x W8 in. x D2 in., \$9,500
- Kenyatta A.C. Hinkle, The Wig, 2014, Collage on Polyfilm, H11 in. x W8.5 in., \$8,082.05.
- Sydney Cain, Black Flight, 2019, lithograph, edition 6 of 6, H19 in. x W15 in., \$1,500
- yétúndé ọlágbaǵú, Our shared horizons #1 - #95, 2022, Photo transfer on travertine stone, Dimensions variable, \$9,000 (Set of up to 30 to be selected from the 95 in the series)
- Erica Deeman, Journey To An Illusion, 2023, Photography, H30 in. x W24 in., \$12,500
- Taller Sanaa (Jessica Sabogal and Shanna Strauss), Serpiente de las Estrellas, 2021, Photopolymer gravure, silkscreen, and gold leaf with chine-collé, H30 in. x W22 in., edition of 2, \$9,000
- Trina Robinson, Crown, 2023, Photogravure, chine collé, handmade palm paper, H14 in. x W11 in., \$8,000
- Myra Greene, To Tailor a Pattern: O1, 2022, Hand dyed and silkscreened textile, H32 in. x W35 in., \$9,500
- Adama Delphine Fawundu, For the Ancestors at Malaga Island #11, #2, #4, #7, #9, #8 (Set of 6), 2023, Monoprint on Silver Gelatin, H16 in. x W12 in. each, \$12,000
- Adia Millet, Integrity (Portal), 2023, Acrylic on panel, H36 in. x W36 in., \$20,000

Item 9: Patricia's Green Temporary Art Project

Discussion and Possible Action

Presenter: Temporary Art & Activation Rebeka Rodriguez Mondragón

Presentation Time: Approximately 10 minutes

Discussion and possible action to approve the display of a sculpture titled Talking Heads, 2019, mirror-polished stainless steel, 18 in. x 7 ft. 6 in. x 7 ft. 6 in. by Oleg Lobykin in Patricia's Green for a period of one year from late June or July 2024 through late June or July 2025, pending approval from the Recreation and Park Department.

Discussion and possible action to authorize the Director of Cultural Affairs to execute a loan agreement with the artist Oleg Lobykin for up to \$40,000 inclusive of honorarium, loan fee, engineering, insurance, transportation, installation, deinstallation and periodic maintenance of the work during the term of its display, pending approval from the Recreation and Park Department.

Oleg Lobykin

(b. 1966)

Talking Heads, 2019

Mirror-polished stainless steel

18' x 7'-6" x 7'-6"



Kristine Mays

(b. 1969)

Not Just Happenstance, 2019

Wire

4 to 5 figures, 65" x 29" x 22" each

before mounting



Public Comment

Item 9: Patricia's Green Temporary Art Project

Item 9: Patricia's Green Temporary Art Project

Action

Motion to approve the display of a sculpture titled Talking Heads, 2019, mirror-polished stainless steel, 18 in. x 7 ft. 6 in. x 7 ft. 6 in. by Oleg Lobykin in Patricia's Green for a period of one year from late June or July 2024 through late June or July 2025, pending approval from the Recreation and Park Department.

Motion to authorize the Director of Cultural Affairs to execute a loan agreement with the artist Oleg Lobykin for up to \$40,000 inclusive of honorarium, loan fee, engineering, insurance, transportation, installation, deinstallation and periodic maintenance of the work during the term of its display, pending approval from the Recreation and Park Department.

Item 10: Portsmouth Square

Discussion and possible action

Presenter: Project Manager Aleta Lee

Presentation Time: Approximately 7 minutes

Discussion and possible action to approve the Project Plan for the Portsmouth Square Improvement public art project.



Portsmouth Square Improvement

PUBLIC ART PROJECT PLAN

MAY 15, 2024
VISUAL ARTS COMMITTEE MEETING

sfac

Portsmouth Square Improvement Project Overview

Centrally located in San Francisco's Chinatown, Portsmouth Square is one of the City's most significant historic, cultural, and civic spaces. The park, located above the Portsmouth Square parking garage, will receive a complete renovation with funding from the 2020 Health and Recovery Bond. The new park design is the result of a robust community engagement and participatory design process and reflects the significance of the neighborhood while addressing programmatic challenges unique to Chinatown.



Walter U Lum Place

Existing Restroom

Stage

Entry Court

Upper Plaza

Clubhouse

Tot Lot Playground

Lower Plaza

Clay Street

Washington Street

z Street













Portsmouth Square Improvement Project Overview

The development of the Art & Interpretive Master Plan was also born out of the community engagement process and will inform the goals and themes of the new public artwork commissions at Portsmouth Square. This interpretive planning process was led by San Francisco Recreation & Parks Department and design consultant Clearstory with input from SF Planning Department, Arts Commission, project architects, and community stakeholders and scholars. Additional funding from Supervisor Peskin's office was granted to the Chinese Culture Center of San Francisco to continue meaningful community outreach efforts throughout the artist selection process.



Key

- Existing Monument
- Amendment Opportunity
- New Interpretation Opportunity
- New Public Art Opportunity

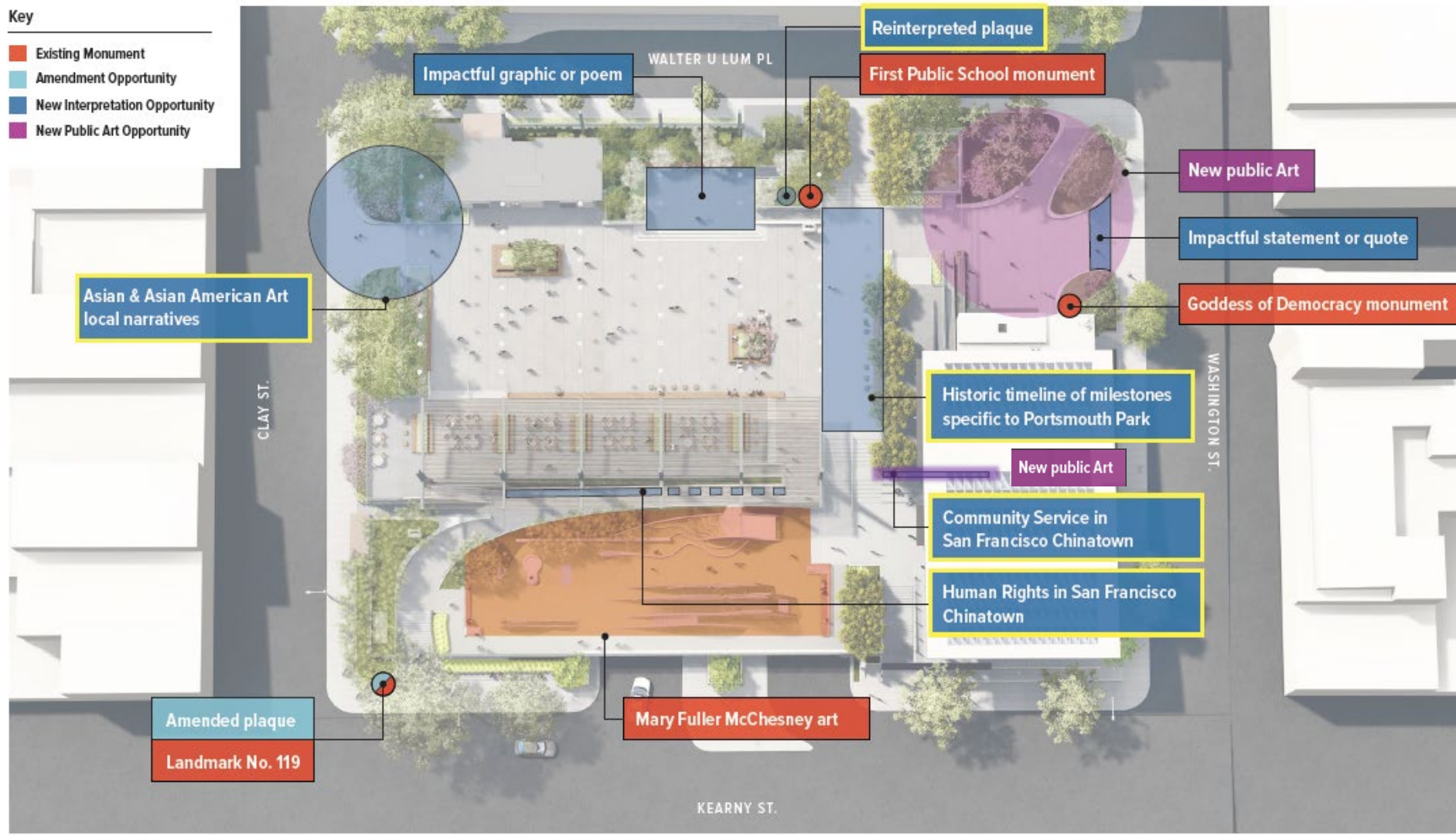

Asian & Asian American Art local narratives

Impactful graphic or poem

Reinterpreted plaque

First Public School monument

New public Art

Impactful statement or quote

Goddess of Democracy monument

Historic timeline of milestones specific to Portsmouth Park

New public Art

Community Service in San Francisco Chinatown

Human Rights in San Francisco Chinatown

Amended plaque

Landmark No. 119

Mary Fuller McChesney art

KEARNY ST.

CLAY ST.

WALTER U LUM PL

WASHINGTON ST.

Portsmouth Square Improvement Artwork Opportunities

1. **Sculpture Opportunity:** Located at the corner entrance of Walter U Lum and Washington Street. Artwork will be a human-scale sculpture and may be comprised of durable, sustainable materials intended for exterior use, such as stone or metal.
2. **Art Wall Opportunity:** Located on the large interior wall of the clubhouse and the adjacent exterior wall by the building entrance from the plaza. Artwork will measure approximately 606 square feet and may be comprised of a durable material, such as mosaic or ceramic tile.

Key

- Existing Monument
- Amendment Opportunity
- New Interpretation Opportunity
- New Public Art Opportunity

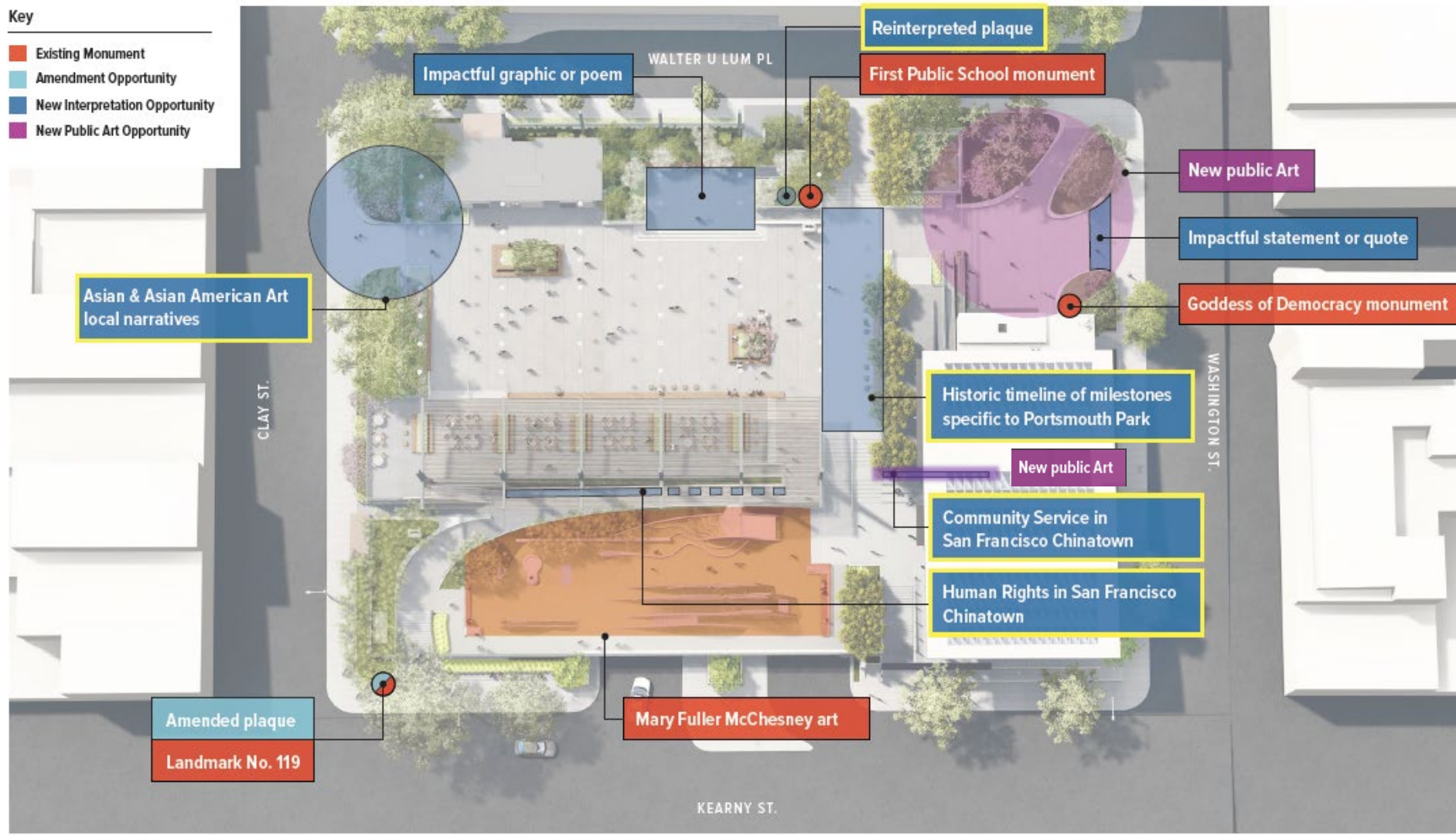

Planting



Ophiopogon japonicus



Pittosporum tenuifolium
"GOLFBALL"



Pinus thunbergii
"Thunderhead"



Pinus densiflora
"Umbraculifera"



Carex chironalis
"Avondale"

Monuments



Goddess of
Democracy Statue

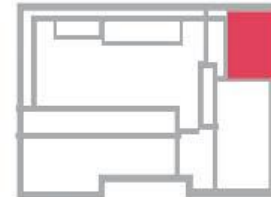

KEY MAP

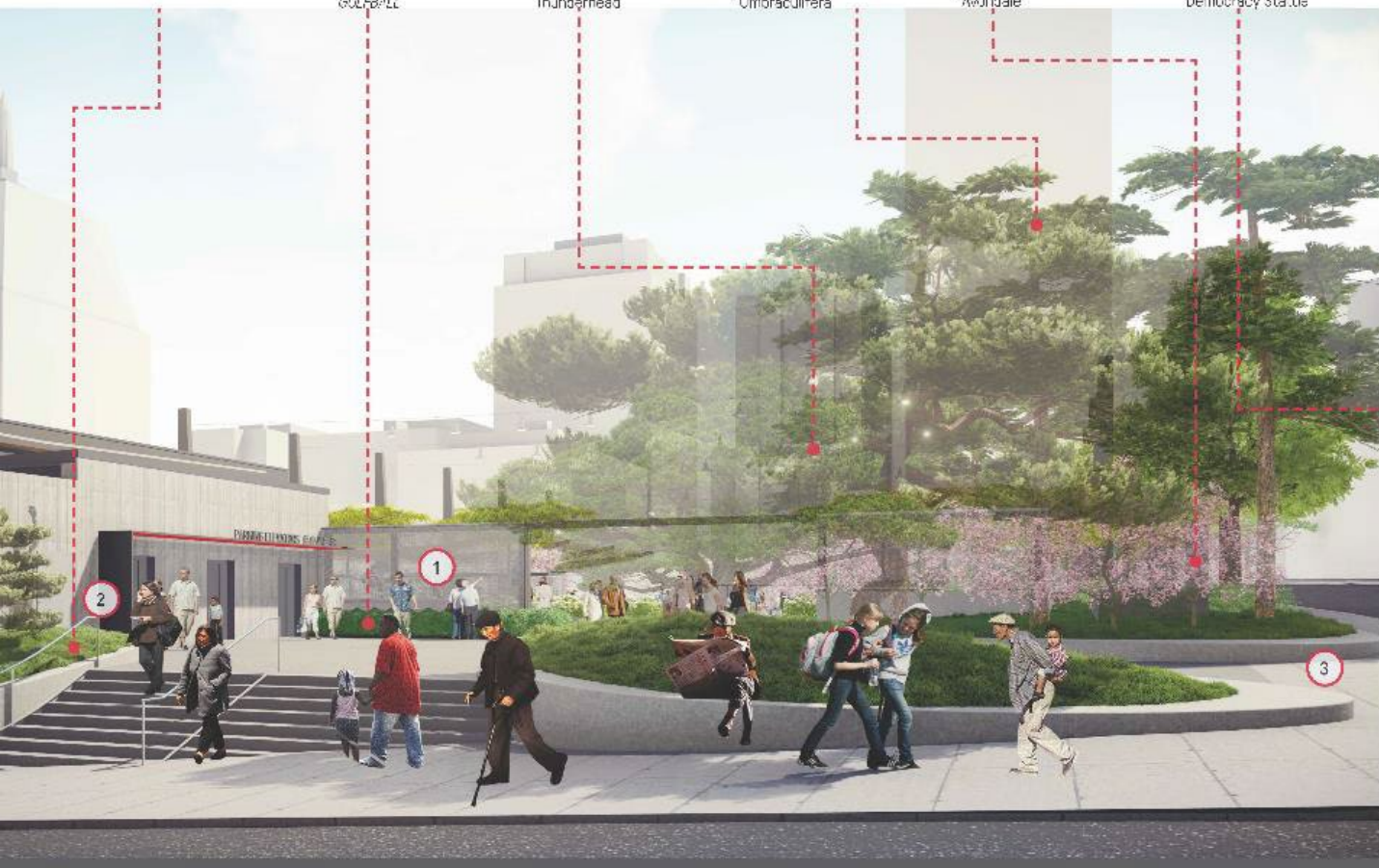

1
Fences and gates



2
Statue of Democracy



3
Entry CIP pebbles

WALTER U LUM AND WASHINGTON ENTRY



GARAGE ELEVATORS ENTRANCE

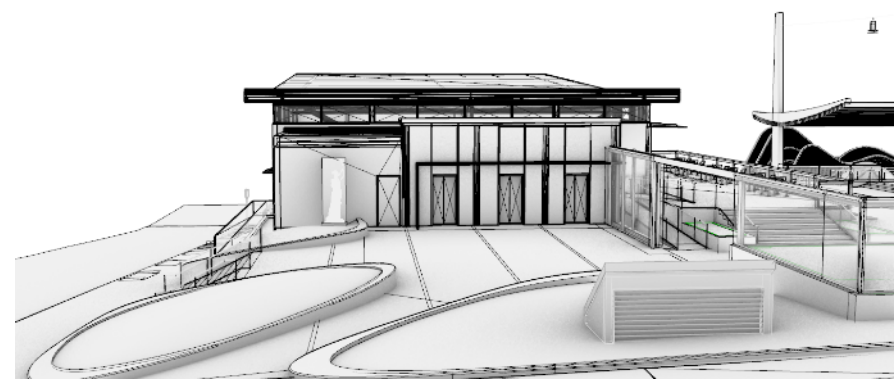

Sculpture Example

Maya Angelou Monument for SF Main Public Library



Maya Angelou Sculpture – Lava Thomas (2023) - \$313,155
Bronze sculpture with basalt stone base (9' x 6.66' x 30")

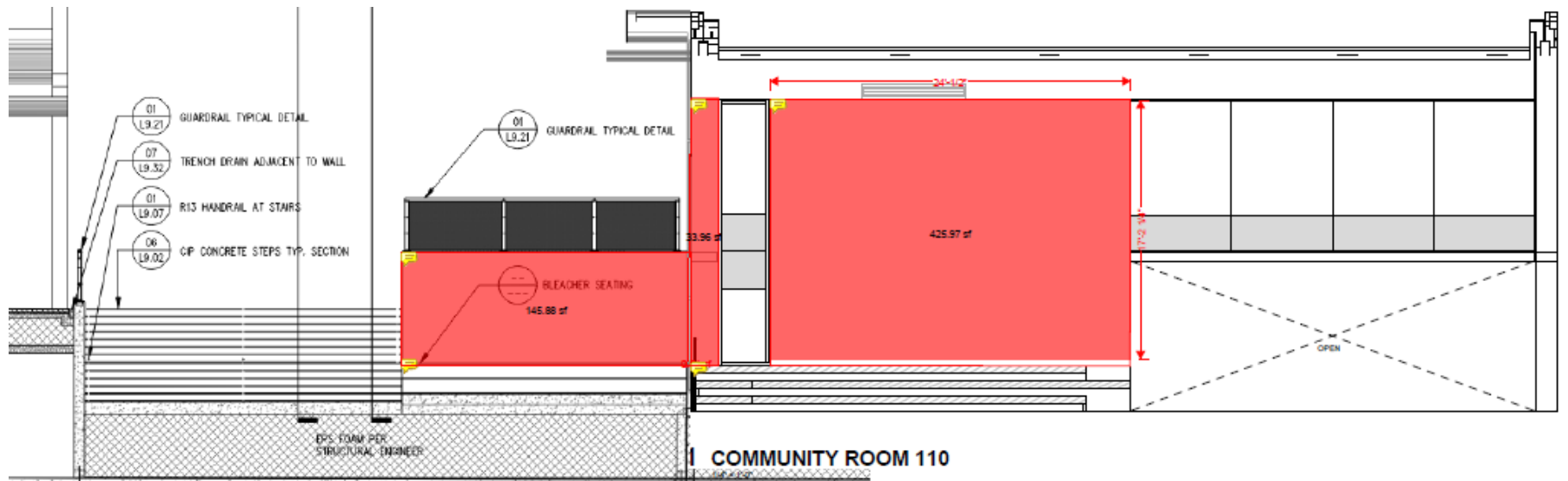



Portsmouth Square Improvement Public Art Project Goals

1. **Sculpture Opportunity:**
 - a. Acts as a welcoming beacon to the Portsmouth Square Plaza
 - b. Is highly visible from the street and draws people into the park space
 - c. Celebrates the people, history, and values of San Francisco's Chinatown communities

2. **Art Wall Opportunity:**
 - a. Reflects community culture and community service in San Francisco Chinatown
 - b. Creates an impactful indoor and outdoor narrative experience
 - c. Bridges and enhances the connection between Portsmouth Square and its new community clubhouse
 - d. Involves a component of community engagement programming led by the selected artist

Budget

Total Art Enrichment Amount: \$921,000

Total Artwork Budget Amount: \$544,000

- **Sculpture: \$340,000**, inclusive of all artist fees, as well as associated expenses for artwork design, fabrication, insurance, transportation, and artist's consultation during installation.
 - Sculpture Installation Budget to be managed by SFAC: \$23,000
- **Art Wall: \$151,000**, inclusive of all artist fees, as well as associated expenses for artwork design and associated community engagement programming, fabrication, insurance, transportation, and artist's consultation installation.
 - Art Wall Installation Budget: \$30,000

Community Involvement

- SFAC staff presented an overview of the public art project in conjunction with the CIP presentation to the community on July 22, 2022, December 2, 2022, August 4, 2023, and February 9, 2024.
- SFAC staff presented updates to the public art project in conjunction with the Art & Interpretive Program presentation to the community on March 29, 2023, October 19, 2023, and January 30, 2024.
- SFAC staff will partner with Chinese Culture Center (CCC) for artist outreach of the Chinatown Artist Registry. CCC will also support artists as a community liaison throughout the Artist Selection Process.
- A community representative will serve on the Portsmouth Square Improvement Artist Review Panel and will participate in the Artist Orientation.

Artist Selection Timeline

Project Plan Approval (VAC)	May 15, 2024
RFQ Issued	June 10, 2024
Artist Application Workshop	July 2024
RFQ Deadline	August 12, 2024
Qualification Panel	Week of August 26, 2024
First Artist Review Panel	Week of September 16, 2024
Artist Finalist Orientation	Week of September 23, 2024
Finalist Proposals Due	November 22, 2024
Public Display of Proposal	December 2 – 16, 2024
Final Project Artist Review Panel	Week of January 6, 2025
VAC Approval	January 15, 2025
Arts Commission Approval	February 3, 2025
Artist Under Contract	March 2025



Public Comment

Item 10: Portsmouth Square

Item 10: Portsmouth Square

Action

Discussion and possible action to approve the Project Plan for the Portsmouth Square Improvement public art project.

Item 11: Staff Report

Discussion

Presenter: Civic Art Collection & Public Art Program Director Mary Chou
Presentation Time: Approximately 5 minutes

Public Comment

Item 11: Staff Report

Item 12: New Business and Announcements

Discussion

(This item is to allow Commissioners to introduce new agenda items for consideration.)

Public Comment

Item 12: New Business and Announcements

Item 13: Adjournment

Action