



INFORMATION SHEET

NO. P-05

DATE : December 10, 2021

CATEGORY : **Plumbing, Electrical**

SUBJECT : **Protecting Utility Lines Traversing New Foundations in Buildings**

PURPOSE: : To provide direction to Department of Building Inspection (DBI) staff, design professionals, and builders for protecting utility lines that penetrate or traverse new footings, walls, and grade beams in buildings.

REFERENCE : Currently adopted Plumbing Code (CPC) Sections 312.10 Sleeves, 1210.1.5 Piping through Foundation Wall, 1210.1.6 Piping Underground Beneath Buildings

Currently adopted National Fire Protection Association (NFPA) 54:7.1.5 and 54:7.1.6

Pacific Gas & Electric (PG&E) 2020-2021 Green Book

Discussion:

When constructing new buildings and renovating existing buildings, utility lines may intersect new foundations, walls, and/or grade beams, causing the need to protect such utility lines during the placement of concrete. The purpose of protecting the pipe is to isolate the utility conduit from damage during construction, possible settlement and lateral movement of the concrete element.

As part of the design process for any new foundation/grade beam in a building, the design professional shall determine the location of existing utility lines within the areas anticipated for excavation. This may be accomplished using the location of existing meters, main connections, and the curb shutoff valves. The location of these conduits shall be shown on the construction drawings, along with the location of meters, main connections, and the curb shutoff valves in the public way.

Prior to excavation, the project sponsor is required to call 811 in order to locate underground piping and other utilities. Once the location of these utility lines is identified, the project sponsor shall determine if they are in conflict with the approved plans. If so, the design professional shall be notified of the issue in order to determine the corrective action.

PG&E has jurisdiction over the lateral gas supply line from the main supply in the street, up to and including the gas meter. Where new grade beams or footings must be constructed around existing gas fuel piping over which PG&E has jurisdiction, the project sponsor shall contact PG&E Building Services to initiate application and engineering design services at (877) 743-7782. Using the PG&E 2020-2021 Green Book as a reference, a design method to protect the existing gas pipe shall be agreed upon with PG&E. A copy of the agreed upon method

shall be provided to the DBI field inspector, prior to placement of concrete, during the reinforcing steel/ok to pour inspection.

Beyond the meter and throughout the building, all utility conduits are under DBI's jurisdiction. In these cases, the design professional shall provide details on the approved drawings showing the method of protecting utility lines through or beneath foundations, walls, and grade beams. A building and any additional required permits shall be obtained and all required inspections shall be performed prior to concrete placement.

The design shall provide specific details for protecting new and existing conduits within or beneath the new concrete element. This detail shall be provided and structurally justified in the design drawings, and verified by plan review and inspection, if different from the prescribed method below.

If no detail exists in the design documents, then a sleeve shall be provided around the utility conduit that is a minimum schedule 40 PVC sleeve with a 1-inch clear annulus between the outside of the utility conduit and the interior of the sleeve (see Figure 1.).

In the case of pipes or conduits penetrating a concrete element and terminating into interior space in the building, the design shall include a detail for sealing the annulus to prevent the entry of water, sewage, or gas into the building.

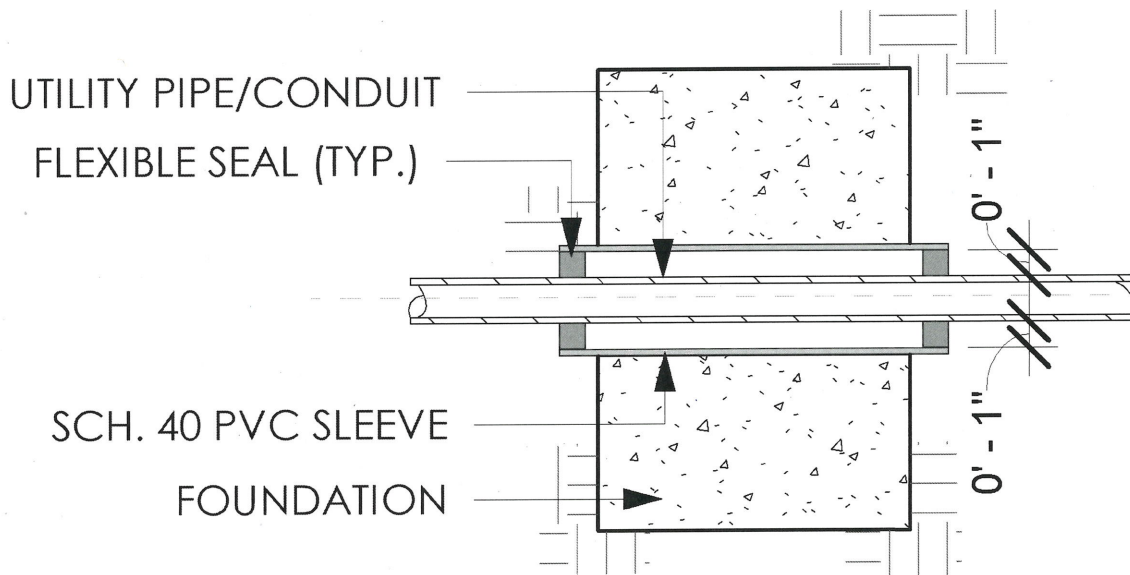

FIG. 1: 1-INCH CLEAR ANNULUS BETWEEN CONDUIT AND PROTECTIVE SLEEVE

Patrick O'Riordan

Patrick O'Riordan, C.B.O.
Interim Director
Department of Building Inspection

12/10/21

Date

This Information Sheet is subject to modification at any time. For the most current version, visit our website at sfdbi.org/information-sheets.