

CITYSIDE PARK
PUBLIC ART PROJECT

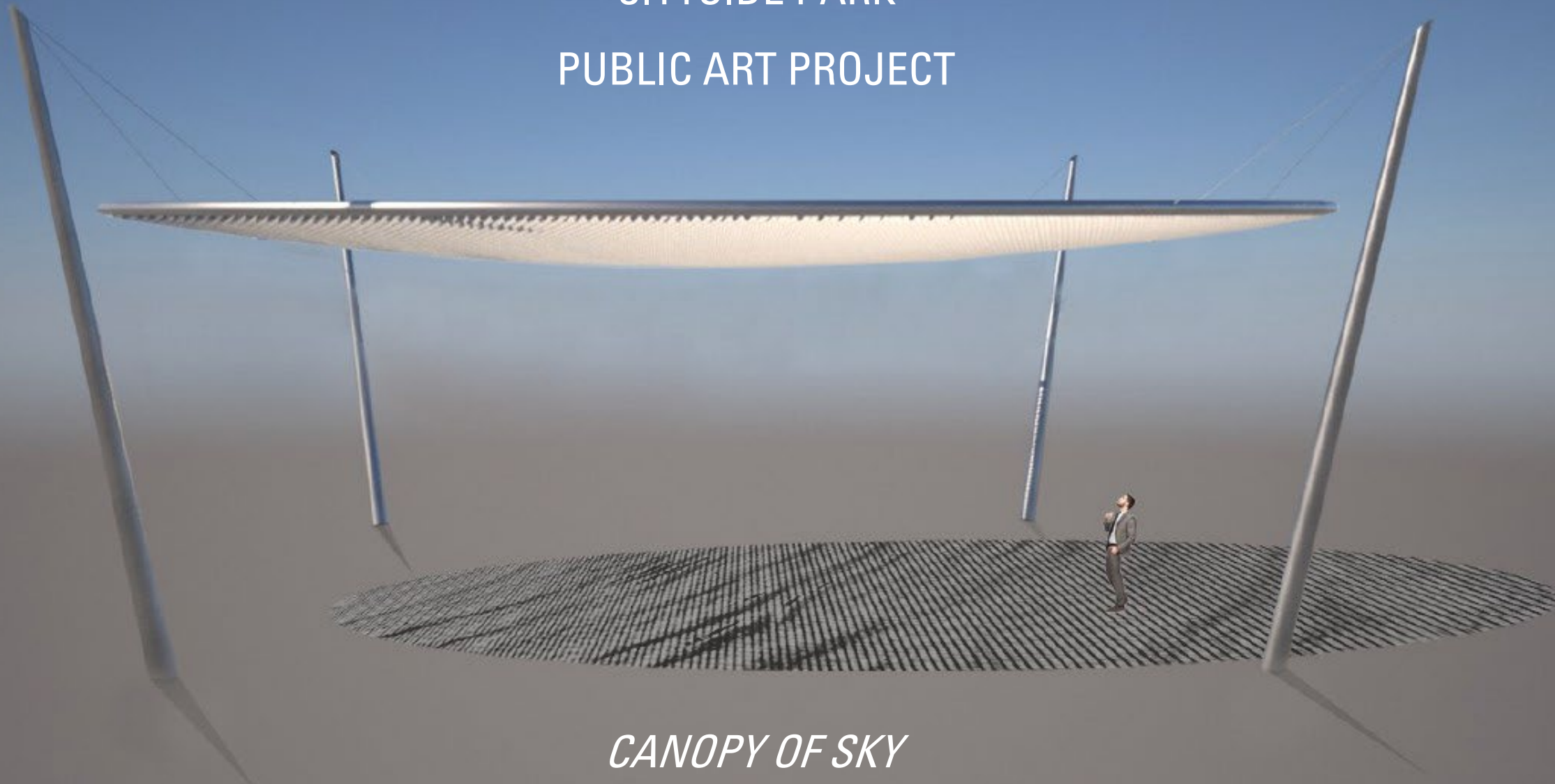

CANOPY OF SKY

NED KAHN

Canopy of Sky

Proposal for Citywide Park, Treasure Island by Ned Kahn

My intent is to create an artwork that opens people up to the magic of the river of ocean air that washes over Treasure Island and hopefully fosters a sense of stewardship towards the delicate envelope of air and water that surround this sphere of rock we call the Earth.

The proposed artwork will consist of a 20' diameter stainless steel ring suspended by cables connected to 4 curved aluminum poles. Stretched across this ring will be hundreds of stainless steel cables populated with 7000 translucent polycarbonate disks that will flutter in the wind like leaves. The translucency of the polycarbonate will capture light and shadow like the droplets of water in fog and clouds. Watching time-lapse video of the fog and clouds allows us to see the constant churning motion, the aliveness of the restless fog. My intent is to create an artwork that is as responsive to its environment, and as fluid, as a passing cloud.

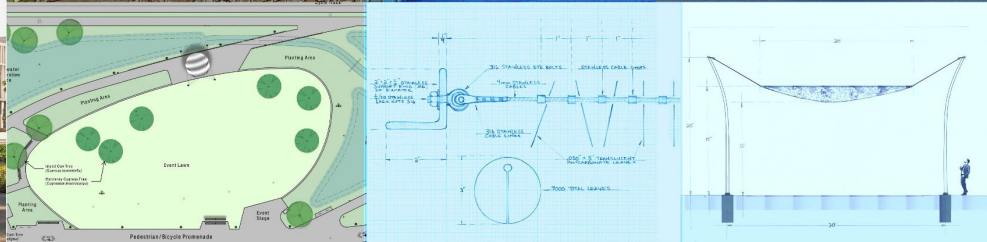
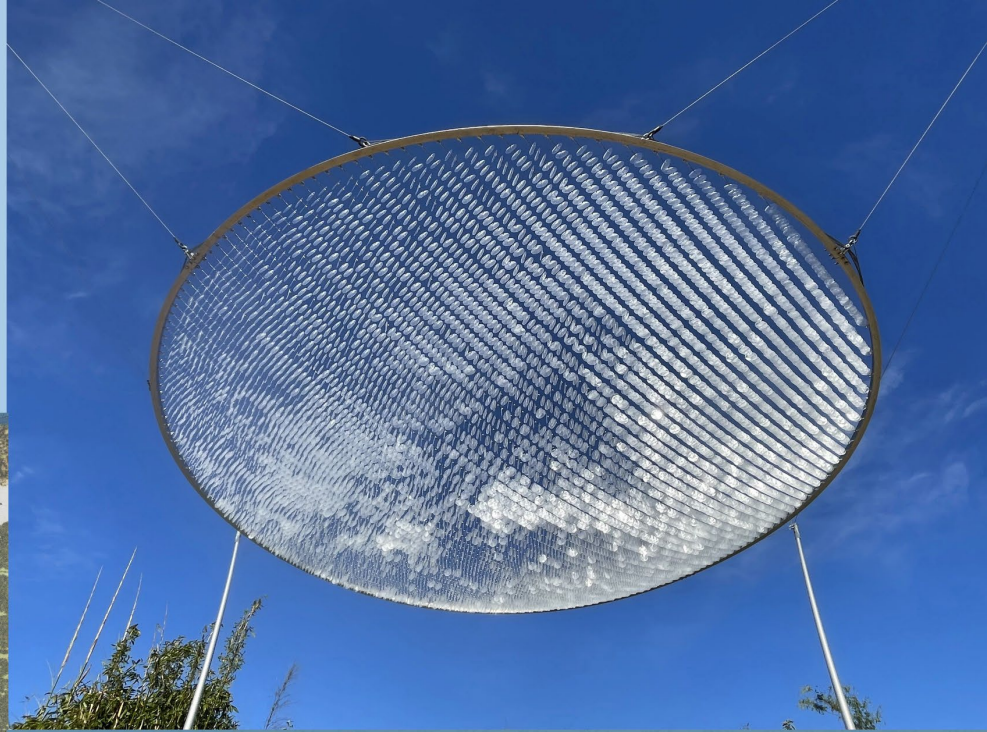
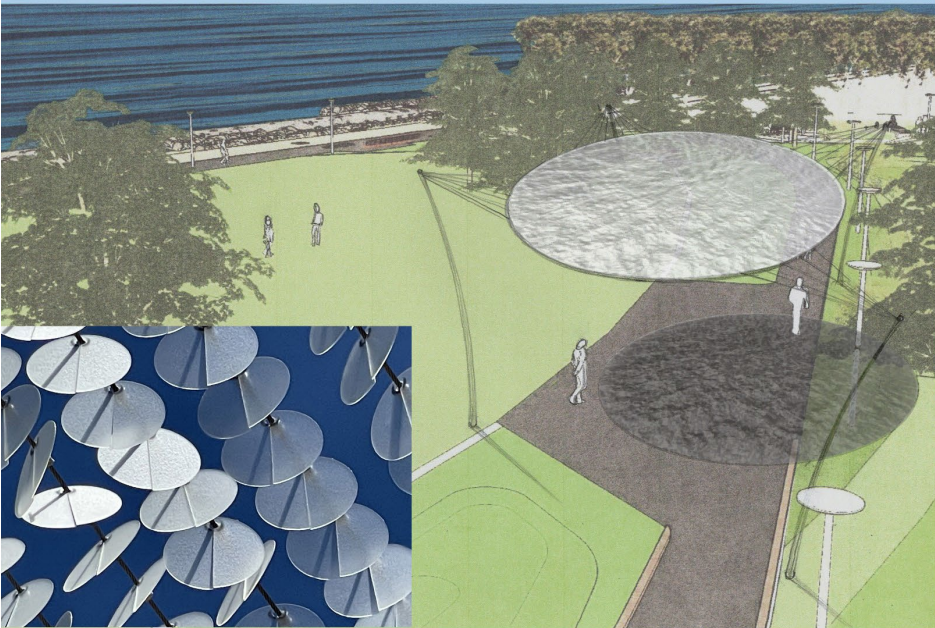



Treasure Island - Cityside Park
Art Location

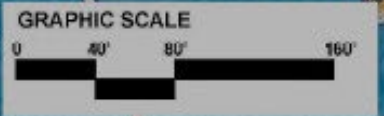

Treasure Island - Cityside Park

Art Location Context Plan

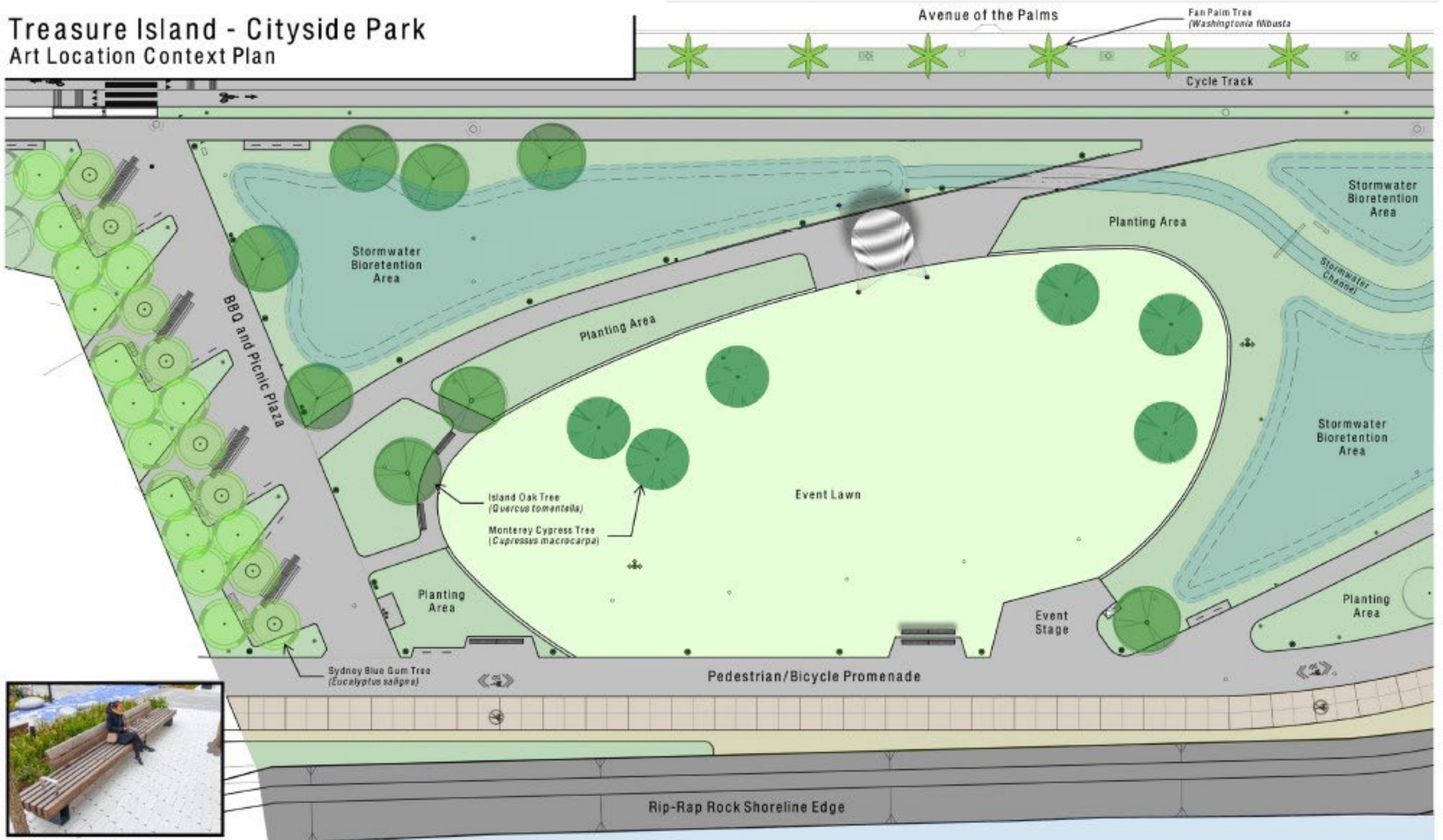

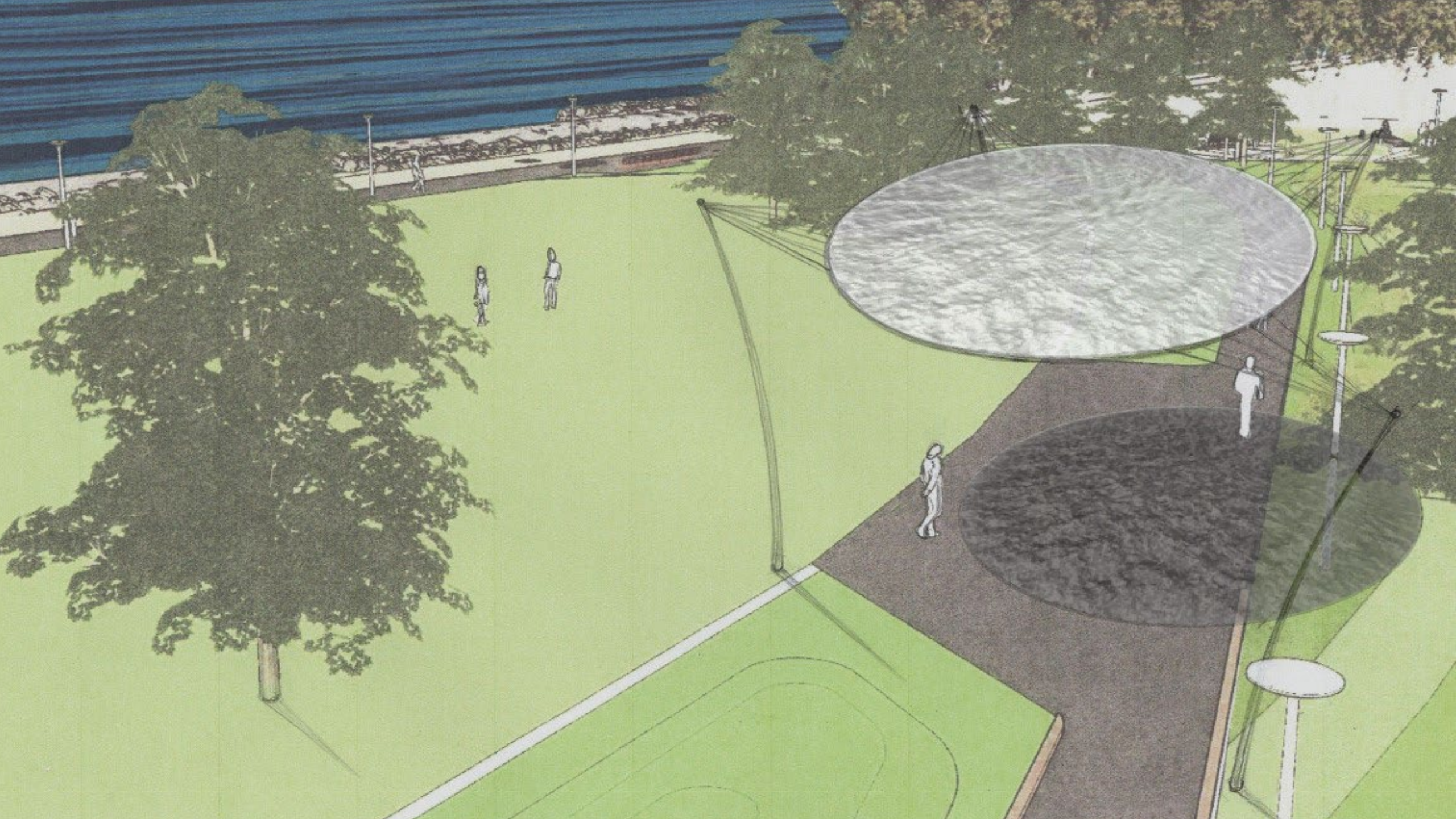







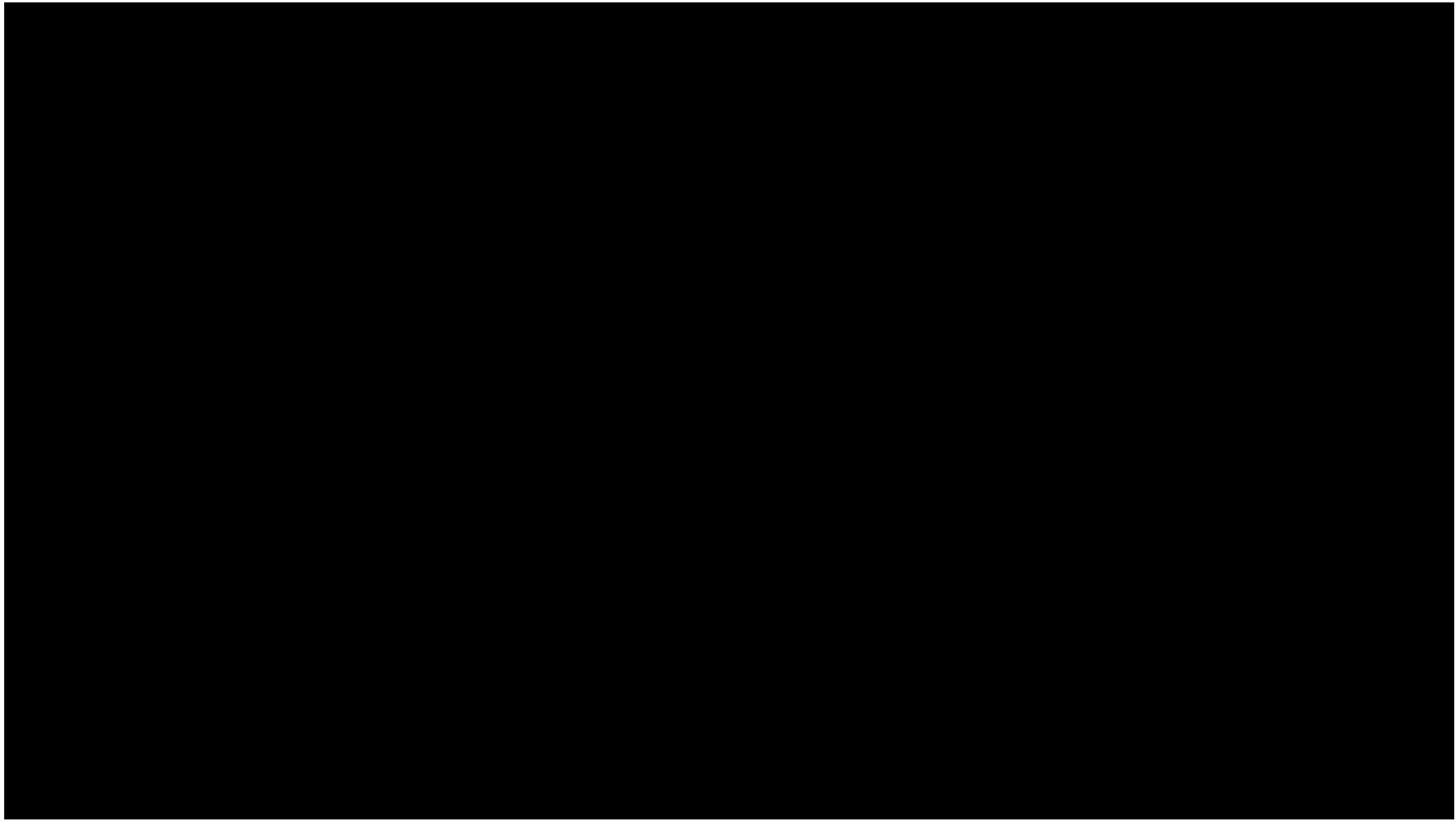

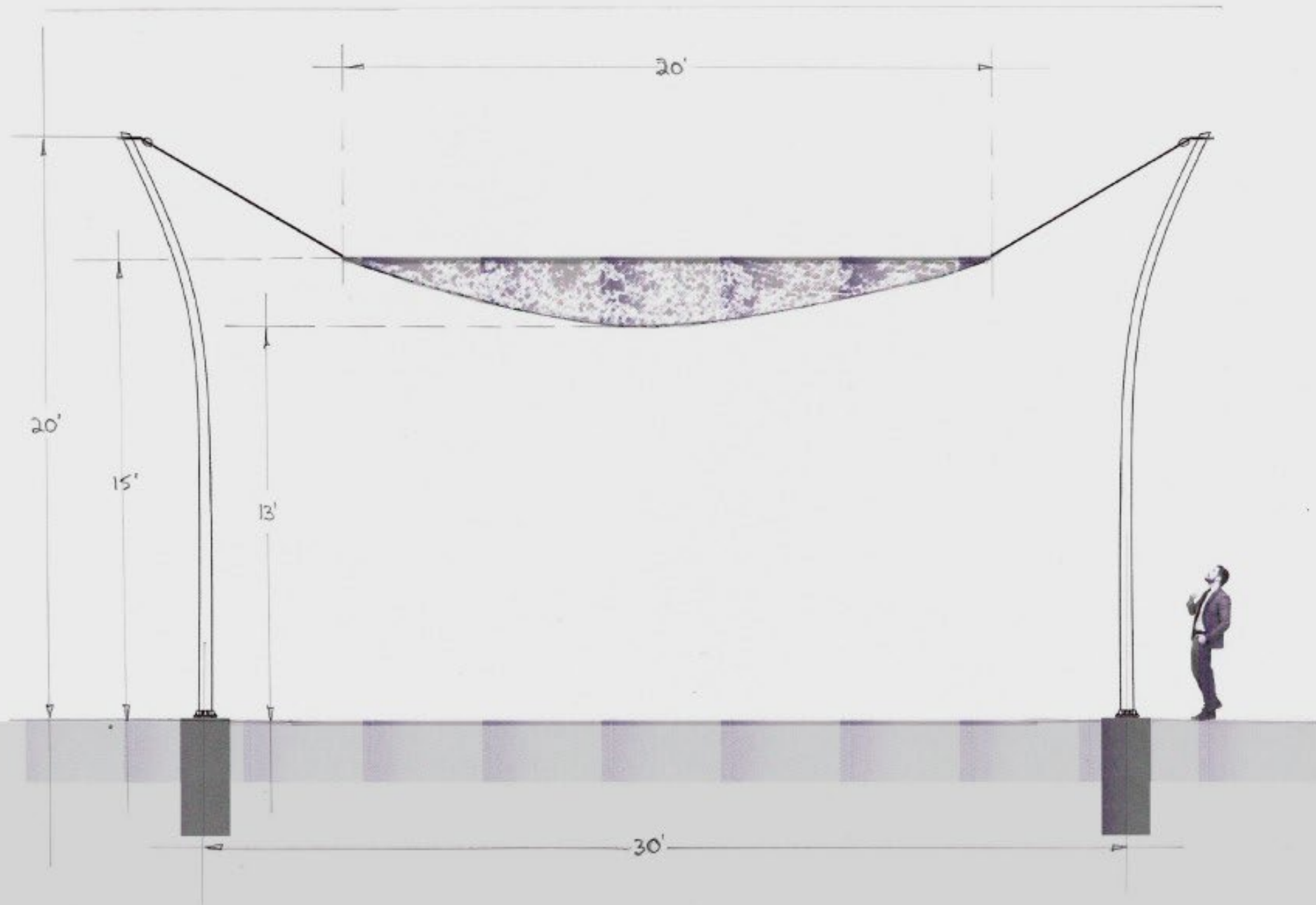

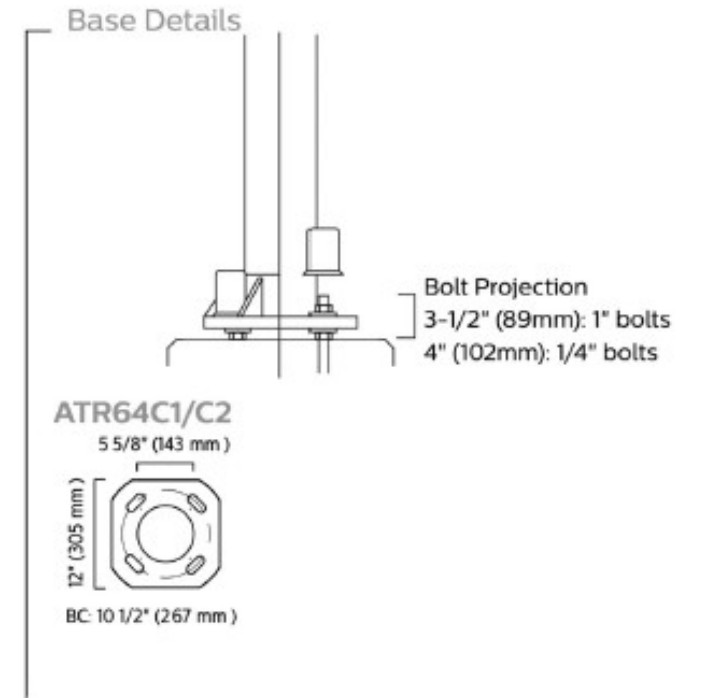
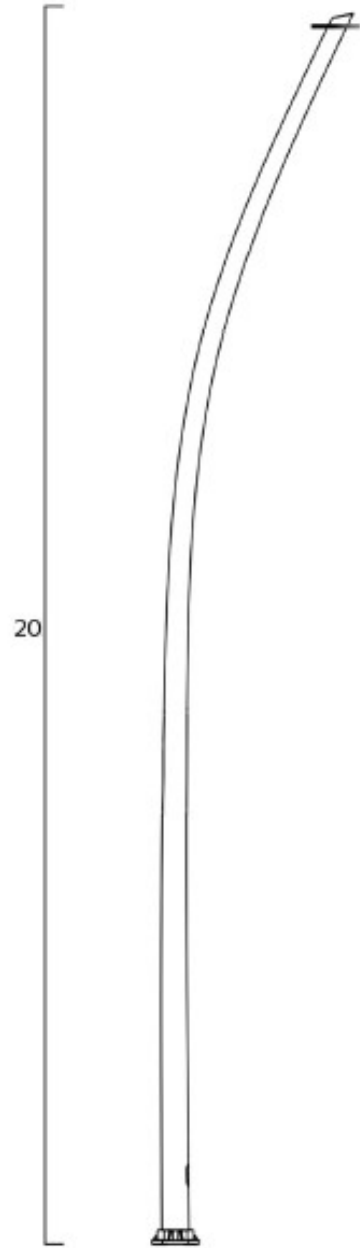
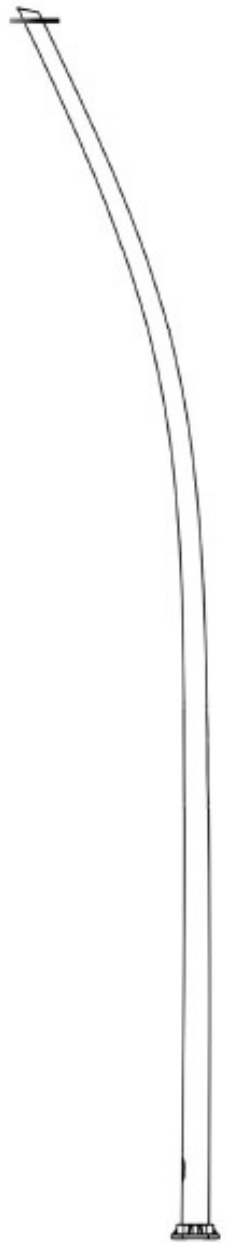

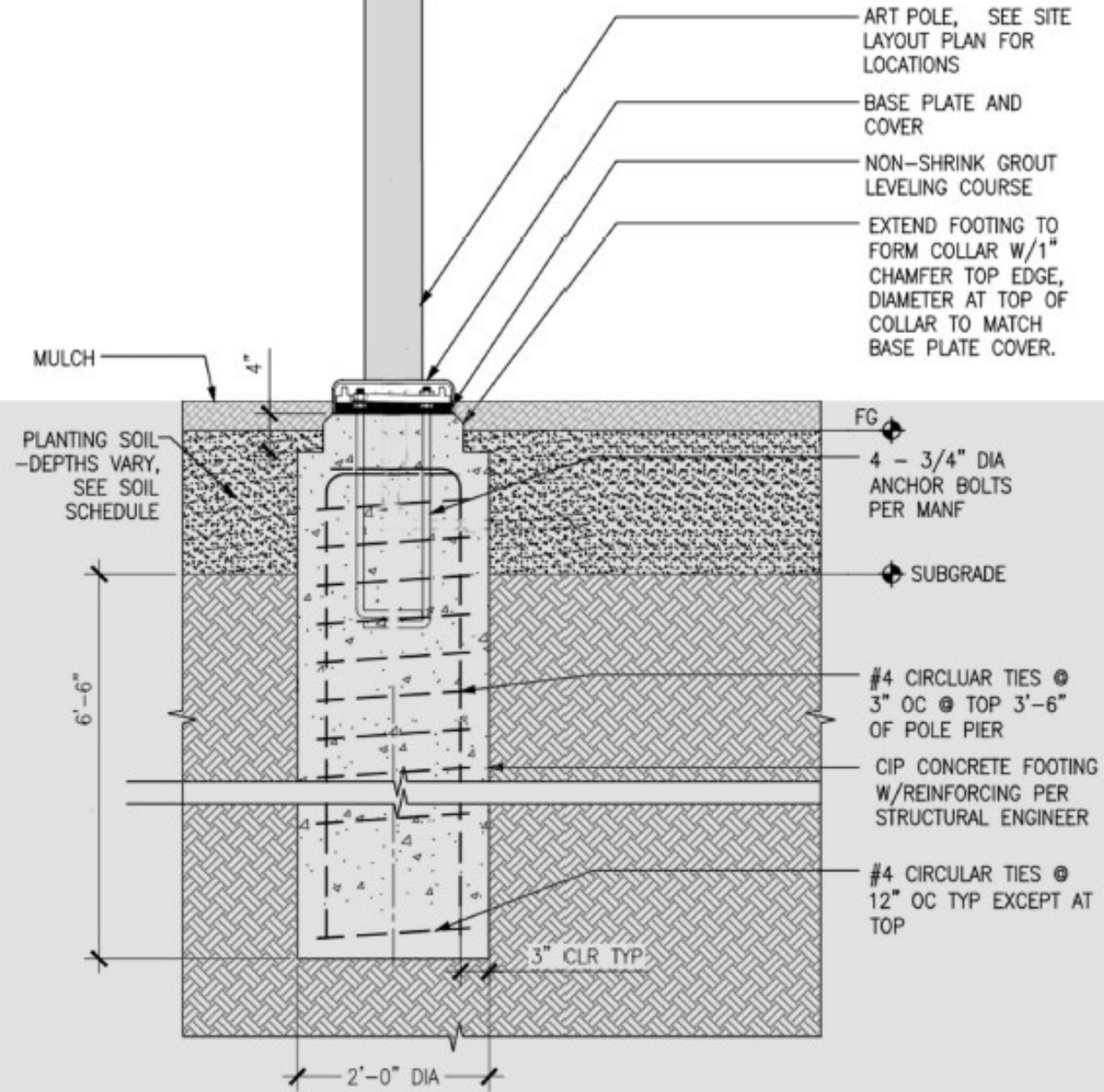

SECTION

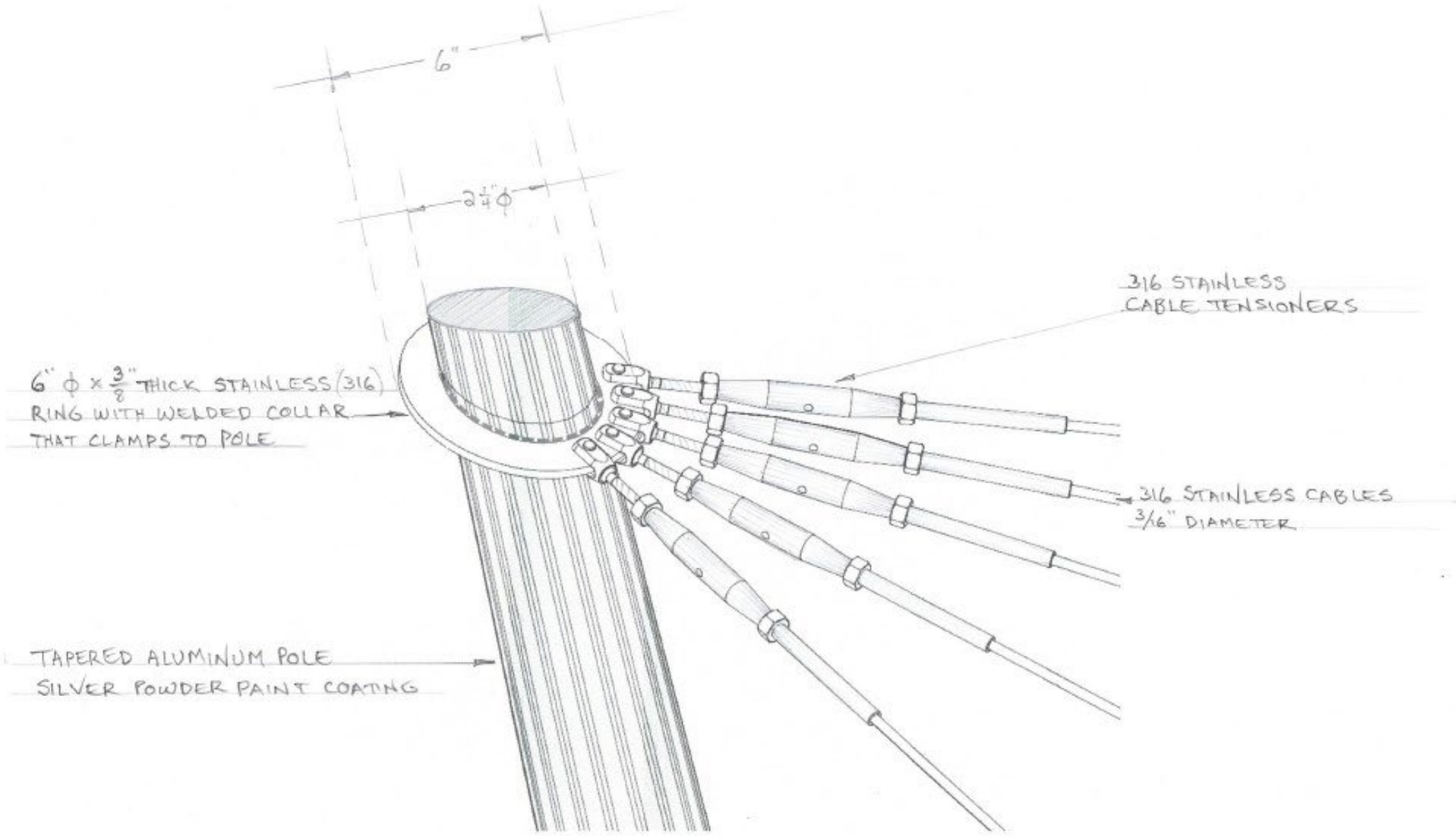

6" ϕ x $\frac{3}{8}$ " THICK STAINLESS (316)
RING WITH WELDED COLLAR
THAT CLAMPS TO POLE

TAPERED ALUMINUM POLE
SILVER POWDER PAINT COATING

316 STAINLESS
CABLE TENSIONERS

316 STAINLESS CABLES
 $\frac{3}{16}$ " DIAMETER

CABLE CONNECTION DETAIL - TOP OF SUPPORT POLES

ALL PARTS 316 MARINE-GRADE STAINLESS STEEL

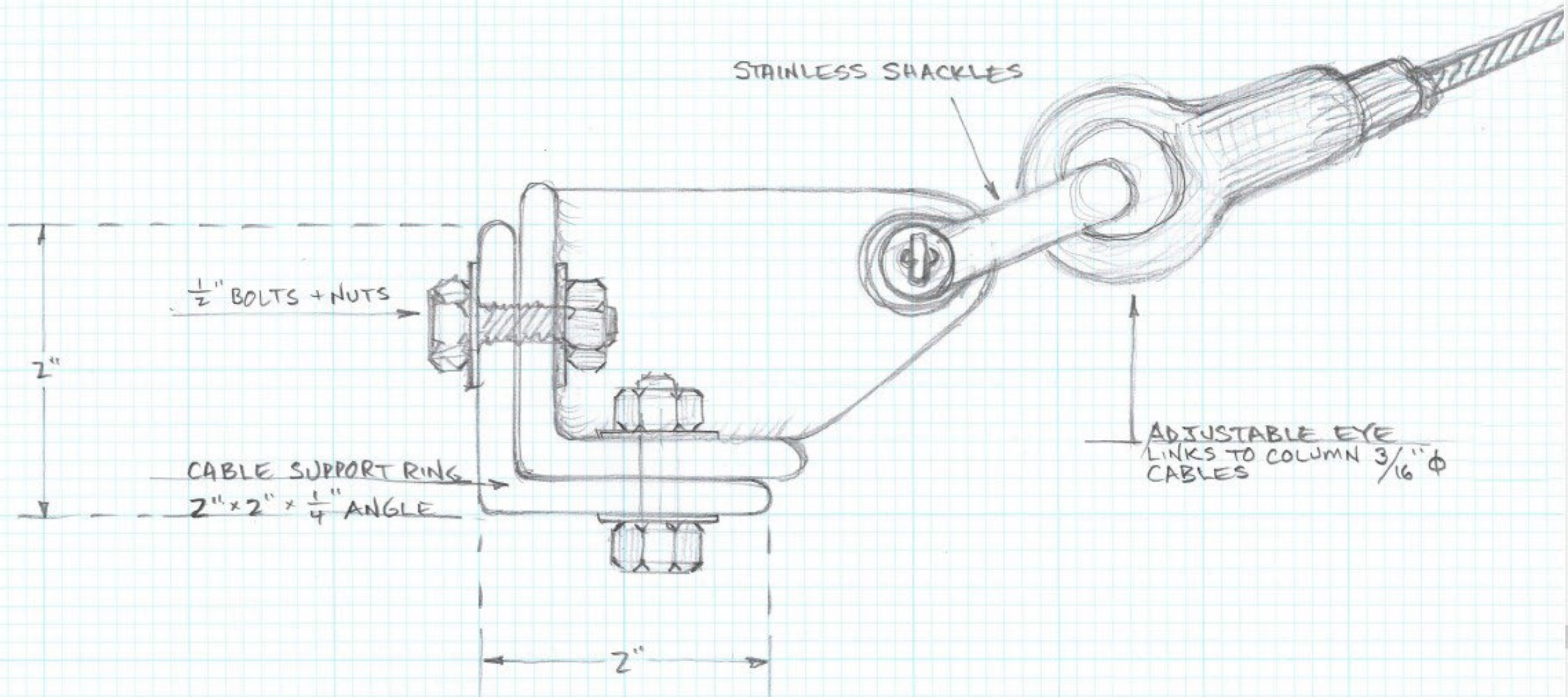

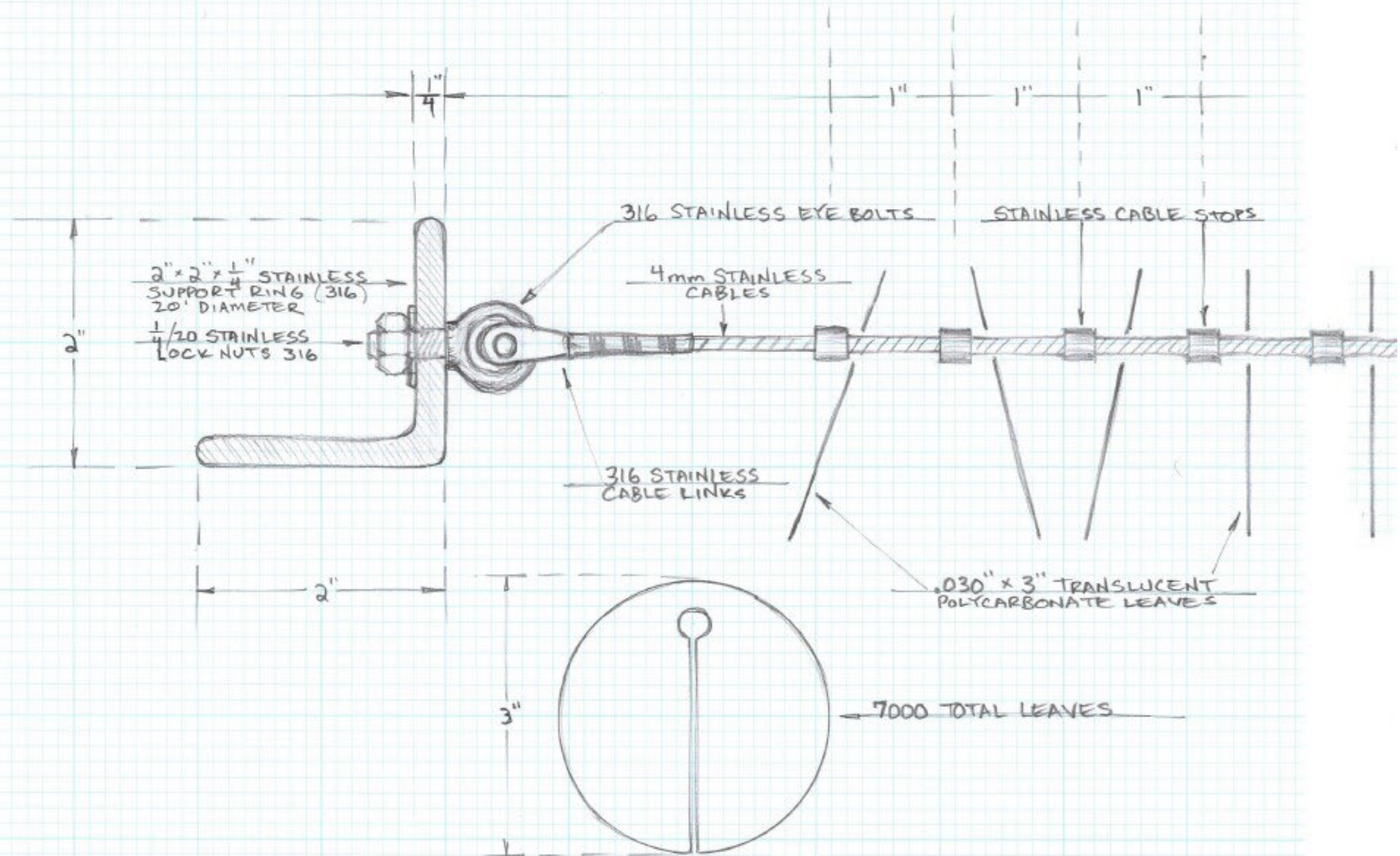

Timeline & Next Steps

May 1, 2023	Site Approval
December 14, 2023 – March 15, 2024	Request for Proposal Period
April 16, 2024	Qualification Panel
May 9, 2024	Selection Panel
June 5, 2024	Finalists Orientation
August 21, 2024	Final Selection Panel
September 11, 2024	TIDA approval of recommended finalist
October 7, 2024	Motion presented to Arts Commission to enter into contract with approved artist.
November/December, 2024	Artist enters into contract with Arts Commission